



PERSPECTIVES IN PRACTICE

Bicycle Detection

A review of available technologies and practical experience to aid in the creation of smarter intersections that work for all users

SUMMARY

Across the United States, approximately two-thirds of reported bicycle crashes happen at intersections. Detecting the presence of people bicycling at or approaching signalized intersections and roadway crossings can offer traffic engineers additional tools and flexibility to improve the comfort and safety for this vulnerable user group. This white paper provides a deeper discussion on the various technologies that are available and provides insight on their strengths, weaknesses and practical applications.

Contributors:

Joe Gilpin, Vice President

Tobin Bonnell, PE, PTOE, Engineering Associate

Matt Fralick, PE, PTOE, Senior Engineer

Kirk Paulsen, PE, Senior Engineer

Lindsay Zefting, PE, Principal



ALTA

As a global leader in mobility innovation for 25 years, Alta helps make positive changes in communities to empower all people to live active, healthy lives. We connect people to places by working across disciplines and scale to address social equity, access, and environmental resilience.

© Alta Planning + Design, 2021.

Bicycle Detection by Alta Planning + Design is licensed under a Creative Commons Attribution-NoDerivatives 4.0 International License.

Disclaimer: The design details, recommendations and conclusions in this document are based on interviews with city staff throughout North America, Alta project experience, and industry design guidance. This white paper uses design resources and discoverable original research by various institutions to make conclusions, though it is possible that other research that may be relevant was not identified. Engineering judgment should always be used in roadway and signal design decisions.

CONTENTS

SUMMARY	1
01 INTRODUCTION	5
Why Bicycle Detection?.....	5
02 RESOURCES	7
03 DETECTION GUIDANCE	9
Loop Detectors.....	10
Push Buttons.....	16
Microwave/Radar.....	20
Video.....	24
Infrared.....	28
In-Ground Radar.....	30
Bicyclist App - Broadcast Presence.....	32
04 ENHANCEMENTS	35
Bicyclist Detector Pavement Markings.....	35
Bicycle Detection Confirmation Indication.....	38
Bicycle Facility Regulatory Blank-out Signs and Warning Beacons.....	40
Physical Amenities To Encourage Detection.....	41
05 CONCLUSION	43
06 REFERENCES	45



01 INTRODUCTION

This white paper is intended as a resource for transportation practitioners who are seeking more detailed information on the various types of signal detection families and the considerations that would impact the selection and configuration of these technologies to detect bicyclists. While guidance on this subject exists, it is fragmented and does not comprehensively provide a full understanding of the capabilities and limitations of each type of detection. This white paper builds upon existing literature on the subject and combines it with practical experience with the hope it will help guide successful intersection projects and expand the industry knowledge base.

Why Bicycle Detection?

In many US and Canadian cities, expanding intersections is either impossible or undesirable. Traffic engineers are being asked to provide intersection solutions that process more users more efficiently while adapting and integrating new facility types like separated bike lanes and dedicated transit lanes. There is a substantial diversity of technologies, both old and new, that give the traffic engineering profession tools to make North American signalized intersections safer, more efficient, and adaptive to changing needs and prevailing conditions. Detecting the presence of bicyclists at signalized intersections can provide many benefits, including:

- Reduction of the need for bicyclists to mount the sidewalk or position in a travel lane to call a signal
- Improvement in signal compliance by people bicycling
- Ability to call exclusive phases, such as bicycle signals, only when actuated to minimize unnecessary delay to other users
- Ability to detect an approaching bicyclist in advance of the intersection and calling a special phase or extended phase timing prior to arrival to minimize bicyclist delay
- Ability to extend the minimum green and/or clearance intervals to allow a bicyclist to safely clear an intersection should the vehicular timing not be sufficient
- Activation of crossing devices such as bicycle specific signals, Hybrid Beacons and Rectangular Rapid Flashing Beacons
- Activation of special electronic warnings for motorists to indicate bicyclist presence (flashing beacons or blank-out signs)
- Facilitate the ability to collect real-time continuous counts of bicycle activity



These bicyclists are waiting outside of the loop detector and may not be detected at this signal



02 RESOURCES

This section briefly summarizes the main industry guidance and studies covering bicycle detection that were consulted prior to drafting the content of this white paper. Additional references and studies are cited throughout this white paper and can be found in the references section.

In 2006, the Federal Highway Administration (FHWA) published the third edition of the *Traffic Detector Handbook*. Chapter 4 of this handbook describes in depth the various types of inductance loop configurations for the detection of large and small vehicles in regards to design considerations and controller operations (FHWA, 2006).

The most current edition of the MUTCD, last published in 2009, has some guidance on signage and pavement markings associated with bicycle detection (MUTCD, 2009).

In 2012, the American Association of State Highway and Transportation Officials released the fourth edition of the *Guide for the Development of Bicycle Facilities*. The guide covers a range of topics from the planning and design to the maintenance and operations of bicycle facilities. In particular, Section 4.12.5 of the Guide gives a quick overview of the different forms of detection methods commonly used at traffic signals, including inductance loops, video detection, and radar. (AASHTO, 2012).

The second edition of the *Urban Bikeway Design Guide*, published by the National Association of City Transportation Officials (NACTO) in 2012 provides design guidelines for the different types of bicycle facilities. The subsection of signal detection and actuation in the bike signals chapter briefly covers the different methods of detection for bicyclists at intersections, but focuses mainly on inductance loop placement and the placement of pavement markings to indicate where bicyclists should stop to achieve the best actuation (NACTO, 2012).

This white paper also utilized the experience of signal professionals at the City of Portland and the City of Austin, as well as several other recent interviews including the City of Fremont. Alta also made contact with many of the equipment vendors to whom we are grateful for their assistance. So as not to be a source of advertisement or favor, this white paper was written to be neutral and does not directly reference any specific vendor or product.

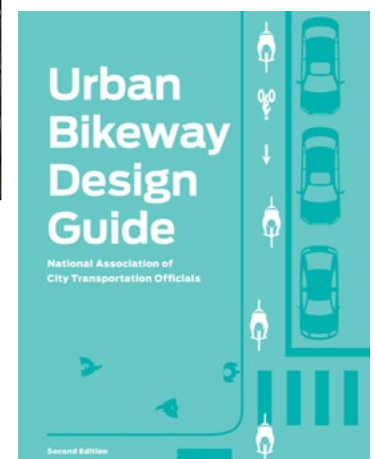
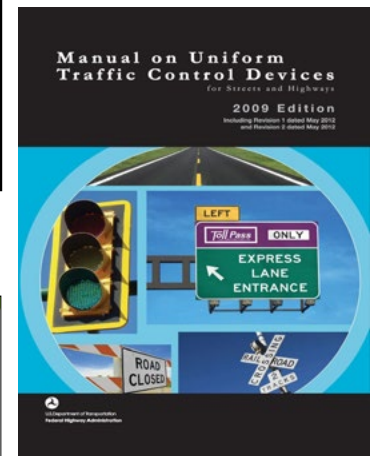
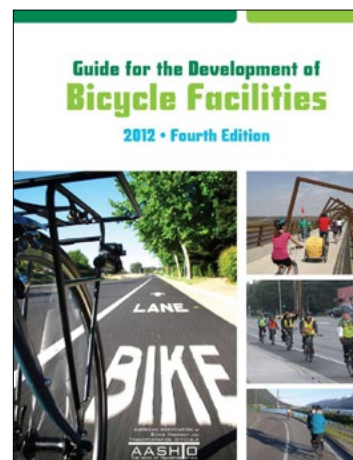
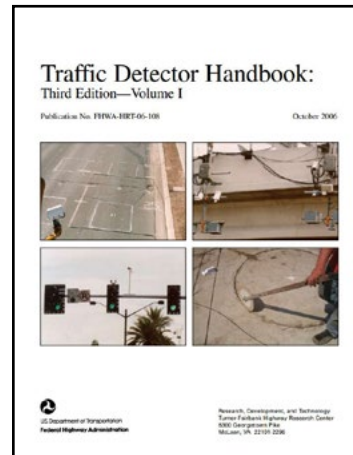



03 DETECTION GUIDANCE

This section provides a detailed summary of each of the common families of signal detection applicable to bicyclists. This resource is intended to provide not only enough detail to understand the basics of the technology, but also to highlight key design, installation, and contextual considerations. Some discussions have an “Additional Technical Detail” section, which provides information that may only be relevant to traffic engineers and signal technicians. Exhibit 1 conveys a contextual detection capability matrix that is specific to the detection of bicycles. Criterion highlighted in green indicates that the detection family is ideal for the context/use. Red indicates that the detection family is not well suited to the context/use. Orange indicates that the detection family may be well suited depending on installation, with additional guidance provided in this section for clarification.

	Push Buttons	Inductive Loops	Video	Infrared Video	Microwave	In-Ground Radar
Capabilities / Limitations						
Detect Bicyclist in Snow/Fog/Whiteout	Green	Green	Orange	Orange	Green	Green
Distinguish Bike from Vehicle (in shared lane)	Green	Red	Green	Green	Orange	Orange
Suitability to Count Bicyclists	Red	Green	Orange	Green	Orange	Green
Suitability to Distinguish Bicyclist Directionality	Red	Green	Green	Green	Green	Orange
Suitability to Detect Low Metal Bicycle	Green	Orange	Green	Green	Green	Green
Suitability to Extend Green or Clearance Time	Red	Green	Green	Green	Green	Green
Shared Travel Lanes						
Shared Travel Lane	Red	Orange	Green	Green	Green	Orange
On-Street Bikeways						
Conventional Bike Lane (at curb)	Orange	Green	Green	Green	Orange	Orange
Conventional Bike Lane (left of right only lane)	Red	Green	Green	Green	Orange	Orange
One-way Separated Bike Lane Approach (Inc Protected Intersection)	Orange	Green	Green	Green	Green	Green
Two-way Separated Bike Lane Approach (Inc Protected Intersection)	Orange	Green	Green	Green	Green	Orange
Bike Box	Red	Orange	Green	Green	Green	Orange
Two Stage Turn Queue Box	Orange	Green	Green	Green	Orange	Orange
Jug Handle (Turn Queue Box)	Green	Green	Orange	Orange	Orange	Green
Raised Bikeways						
One-way Separated Bike Lane Approach	Green	Green	Green	Green	Green	Green
Two-way Separated Bike Lane Approach	Green	Green	Green	Green	Green	Green
Shared Use Path (differentiate bikes from pedestrians)	Green	Green	Red	Red	Orange	Orange
Bicycle Specific Crossing Treatments						
Toucan Crossing	Green	Green	Green	Green	Orange	Green
RRFB or PHB Crossing from curb	Green	Green	Orange	Orange	Orange	Orange

- Ideal candidate for use
- Can be configured depending on context, may not be ideal or may require additional detectors
- Generally not suitable for context

Loop Detectors

Controller Compatibility	High
Installation Complexity	Moderate to High
Functionality	Presence (Yes) Counts (Yes) Directionality (Yes) Distinguish Multiple Bikes (No)
Durability	Depends on surrounding material (asphalt/concrete), and climate (extreme heat or freeze/thaw cycles)
Ideal Applications	Anywhere a bicyclist is in an exclusive space and the loop can be tuned accurately

Strengths

- Low cost
- Reliable
- Different winding patterns depending on context
- Can be used for both vehicles and bicyclists
- Can be configured to provide counts
- Accuracy not impacted by weather conditions
- Can be used to call bicycle-specific crossing devices from shared areas with pedestrians

Weaknesses

- Installation requires lane closures
- Freeze/thaw conditions can lead to pavement cracking around the saw cut
- Extreme heat that can deform asphalt can impact loop function
- Shared lanes with large volumes of heavy vehicles can result in warped pavement and broken loops
- Sealant can pull out and water damage can occur
- Can pick up false activations from adjacent lanes
- May require sensitivity adjustments to ensure proper working order

Overview

Inductance loops (loops) are one of the most commonly used methods of detecting large and small vehicles on roadways. They are relatively inexpensive and provide a high level of reliability for detection. Inductance loops consist of an electrically conductive wire loop that is formed into a pattern inset in the pavement. An alternating current runs through the loop, creating an electrical circuit with inductance. Inductance is defined as the property of an electric circuit by which an electromotive force is induced in it as the result of a changing magnetic flux. Based on this property, when a ferrous item, such as a vehicle, overlaps the circuit, the magnetic flux changes and can be measured. A detector card inside the traffic signal cabinet measures this change and places a call to the signal controller.

Many states require detection of motorcycles and bicycles at intersections, as to not trap these users on actuated approaches and create compliance issues. With some modern bicycles being constructed mainly of carbon fiber, aluminum, or other non-ferrous materials, engineers prefer certain loop patterns that create “sweet spots” with a higher number of wire turns and the most potential to detect the change in inductance. To help position bicycles in the best location, pavement markings can be used to indicate the optimal position to place the bicycle for detection. See later section on detector symbol markings.

Installation considerations/implications

The installation of loops is straightforward but requires lane closures for approximately two to four hours per installation. Installation consists of sawcutting the shape of the desired loop path into the pavement approximately two to four inches (five to ten centimeters) deep. Once the sawcut is blown clean, the wire can be wound in and compressed into the sawcut using a specialized wheel or other tool. Once the number of turns specified is achieved, a foam or sealant is placed on top to prevent water damage. Conduit and two-pair wire leading from the controller to a pull box on the side of the road adjacent to the loops will need to be provided to splice the lead-in wire from the loops to the two-pair wire in the pull box connecting to the controller.

Pattern Configuration

The three most commonly used patterns that have been designed to detect bicycles are the “Type D” loop, the “Type Q” loop, and the Parallelogram loop. The “Type D” and “Type Q” loops were eventually adopted by Caltrans (California Department of Transportation) and further tested by the FHWA in the study “Making Signal Systems for Cyclists” (2008). Other commonly used patterns for motor vehicle detection include the “Type A” (square) and “Type E” (circular). Both of these patterns are not optimized for bicycle detection and have narrow “sweet spots.”

“**Type D**” loops were created to help detect bicycles and motorcycles better than standard loops for vehicles. In most loop patterns, the optimal place for a bike to be detected is directly on top of the saw cut. The “Type D” loop is constructed diagonally to the travel lane so that when a bicycle enters the loop, they will automatically be positioned for the best detection. Per further studies (Shanteau, 2008), the “Type D” loop does an excellent job of rejecting vehicles in adjacent lanes. One issue with these types of loops are the sharp turns required based on the pattern during installation.



Type D Loop in Huntsville, AL

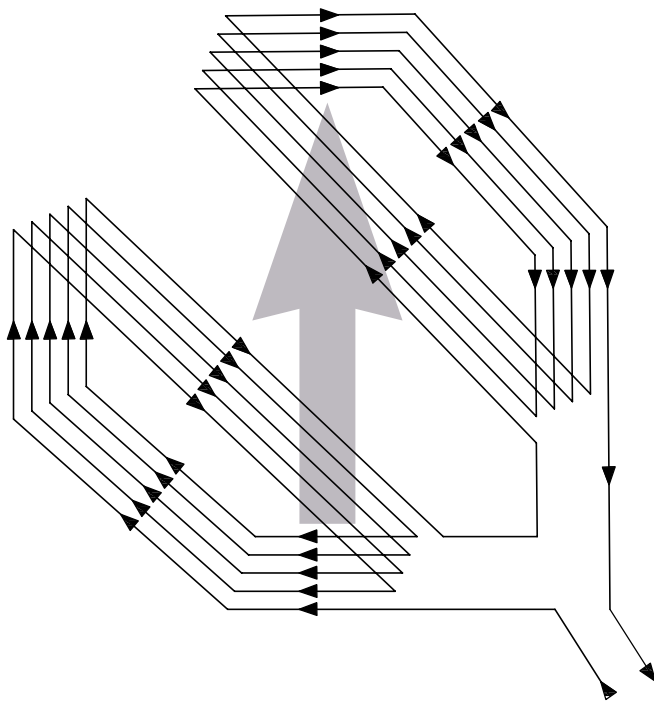

Winding Detail

Type D Loop Detector Configuration

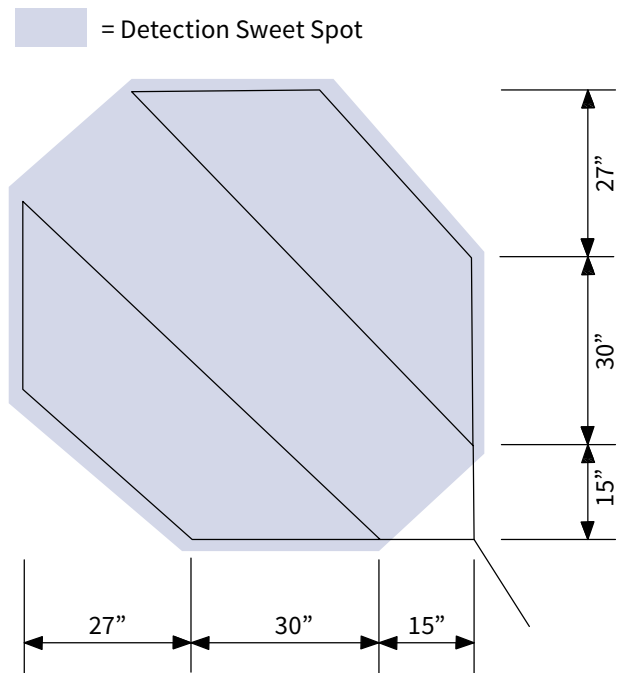

Sawcut Detail

“Type Q” loops are modified quadrupole loops that help detect bicyclists better. A quadrupole loop is a pattern of loop that allows the magnetic field to have four magnetic poles. Based on this design, bicyclists would have to ride directly over the saw cut to have the best chance of being detected. The “Type Q” loop was designed to be a six-foot by six-foot pattern cut into two separate three-foot by six-foot rectangles and rotated to be perpendicular to the travel lane. By adjusting the shape of the rectangle and the rotation of the saw cut, this allows the optimal detection zone to be directly in the travel path of bicyclists. Like “Type D” loops, the “Type Q” loop does an excellent job of rejecting vehicles in adjacent lanes (Shanteau, 2008). Additionally, the “Type Q” loop is easier to install and does not require the same sharp angles as the “Type D” loop. One disadvantage to the “Type Q” loop is that bicyclists just off the loop will not be detected due to the wrapping of the wires and partial cancellations of the magnetic field.



Type Q Loop in San Luis Obispo, CA

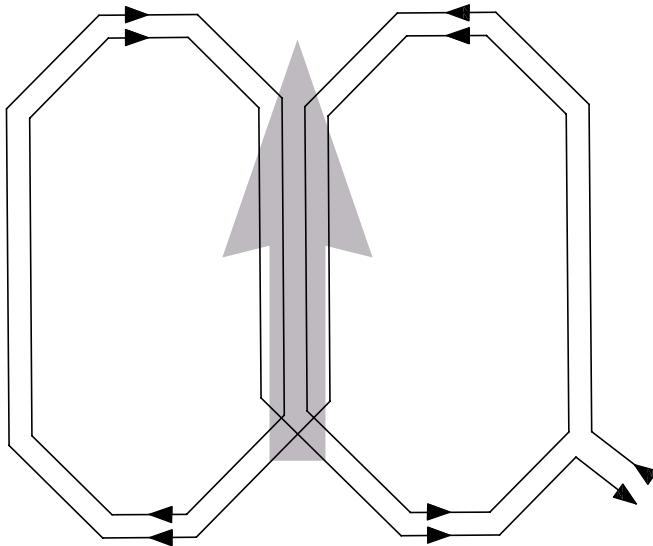

Winding Detail

Type Q Loop Detector Configuration

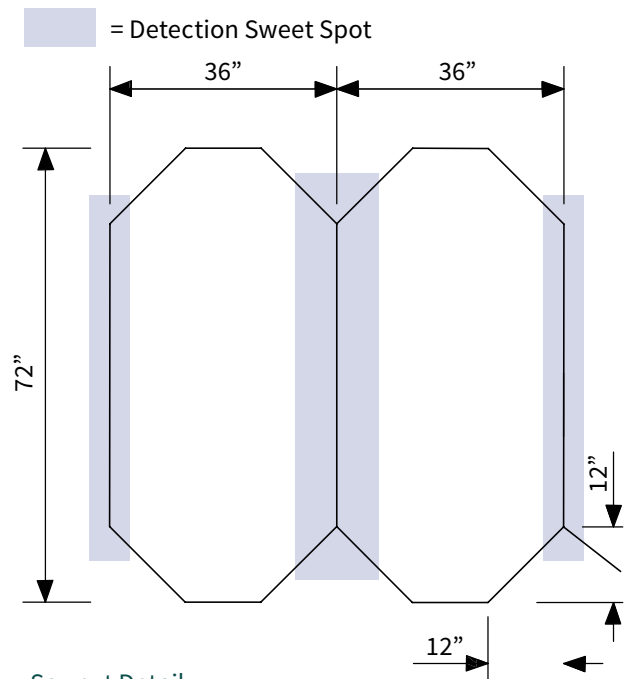

Sawcut Detail

The **parallelogram loop** is simpler to install than the “Type D” loop and provides reliable detection for bicycles. The loop can also differentiate between bicyclists and motor vehicles by the characteristics of the change in inductance. The parallelogram loop can be a variety of widths and three to six feet long, set at a 45 degree angle for shared use lanes, or can be four feet wide with the remaining dimensions constant to fit in a bike lane. The sawcut detail below depicts two pattern types for a shared lane use or in a bike lane. Based on the shape of the parallelogram loop, bicycles will naturally pass over the sensitive points on the loop, providing reliable detection.



Parallelogram Loop Detector Configuration in Portland, Oregon detects bicyclists and vehicles entering this mixing zone. This location puts in a locking call and extended green for bicyclists. (Credit: Oliver Smith)

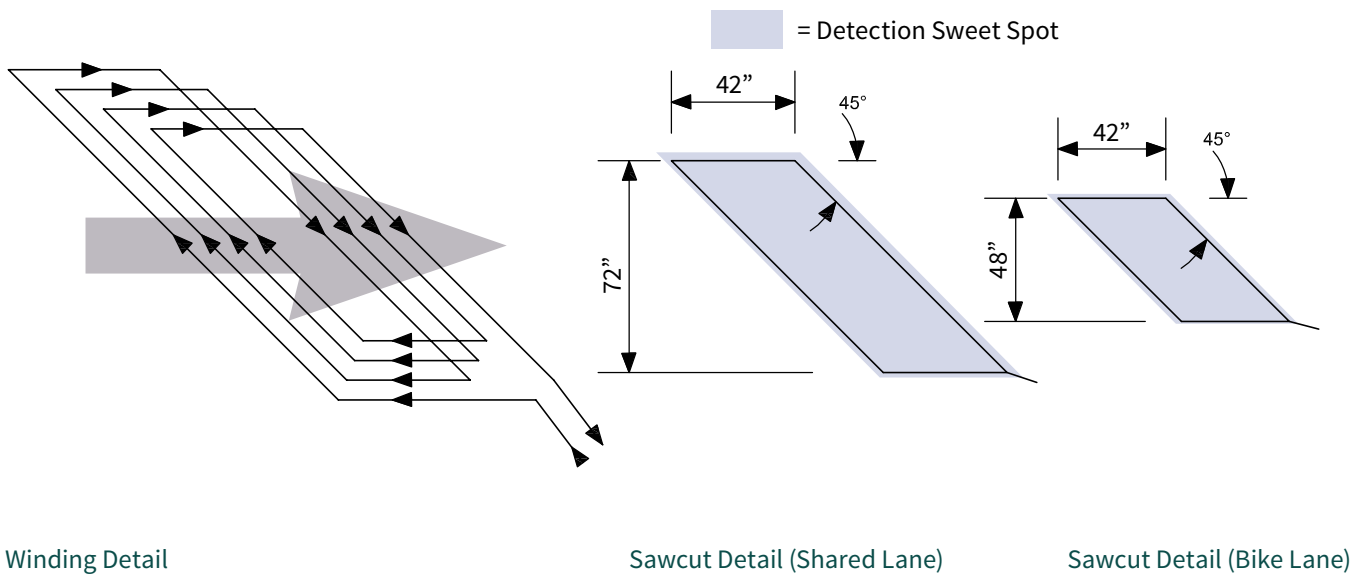

Winding Detail

Sawcut Detail (Shared Lane)

Sawcut Detail (Bike Lane)

Parallelogram Loop Detector Configuration

Location

One disadvantage of loops is that bicyclists must be correctly positioned to travel over or stop on top of them, or they will not work reliably.

Stop Bar Loops

Stop bar loops, such as the “Type D” or “Type Q,” should be installed if a dedicated bike phase is provided, within bike boxes, and within a shared lane if detection is required for the approach. Stop bar loops should be installed at the stop bar in the location where bicyclists are most likely to stop. If a bike box is provided, additional inductance loops can be provided to ensure detection of bicyclists anywhere in the box. Bicycle detector pavement markings are also recommended where the stop location may not be obvious or reliable.

If the approach to the intersection is a shared lane, a “Type D” or “Type Q” loop would detect both bicycles and vehicles equally. If a different type of loop pattern is used (such as a more vehicular-oriented circle or square loop), it is highly recommended to install a pavement detector marking to indicate to bicyclists the best place to stop.

Shared Use Lane Loops

The parallelogram loop is often used in a shared lane and provides a reliable detection for both vehicles and bicycles. Due to the pattern of the loop and setting it in advance of the stop bar, bicycles will inherently pass over the loop. Additional loop patterns such as the circular loop with the MUTCD Figure 9C-7 pavement marking (See “Enhancements” Section) have been adopted by some agencies for shared lanes.

Advance Loops

If advance loops are desired at the intersection, loops should be placed at a distance determined by speed and the design criteria in advance of the stop bar in the bike lane. The “Type D” or “Type Q” loop should be used for optimal detection of bicyclists upstream in a bike lane or two-way cycle track. The parallelogram loop can be used as an advanced detector in a bike lane based at a distance specified by an agency’s standards. If obtaining counts is desired, a loop should be placed in an area where bicyclists will not queue on the detector. If directionality is desired, two loops in succession can provide the logic necessary to differentiate directions.

KEY TIPS

The City of Austin has limited bicycle loop use to places where the bicycle waiting area is confined and the reliability of bikes stopping over the loop is maximized.

Austin experiences extreme heat at times and has found that loops are the most durable when cut into concrete as opposed to asphalt, where the surface can distort in the heat.

The City of Portland has a troubleshooting bike and standard process that they use to calibrate loops to detect bicycles.

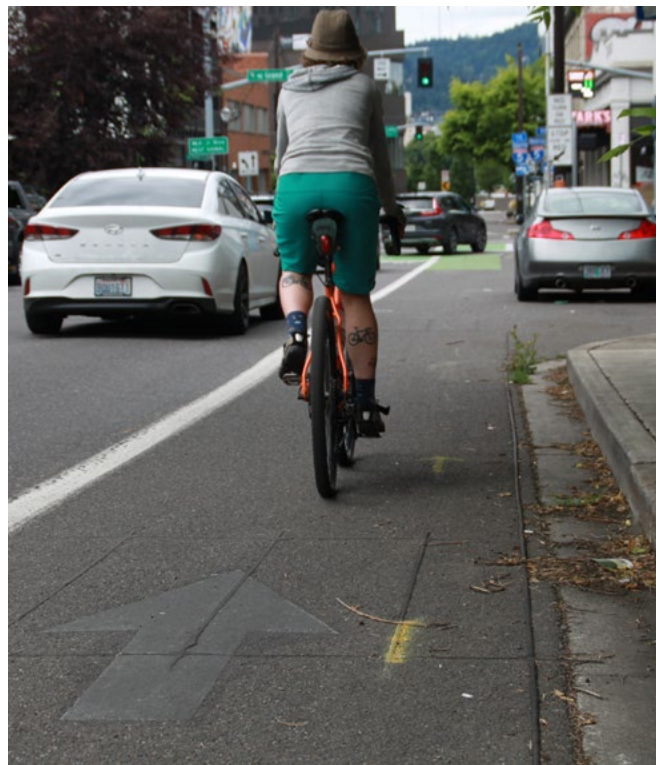

This advance loop in Portland, Oregon detects bicyclists in advance of the intersection.

ADDITIONAL TECHNICAL DETAIL

One benefit of installing inductance loops is the ability to work with all National Electric Manufacturers Association (NEMA) standard TS-1 and TS-2 cabinets, as well as the California Department of Transportation Traffic Engineering Electrical Specification (Caltrans TEES) cabinets, which are commonly referred to as a 332 or 336 cabinet. Upgrades to a controller or signal cabinet usually only occur when trying to provide more phases than the cabinet or controller is specified for, out-of-date equipment from what the agency typically stocks, or intersection redesigns.

Detector cards for loops are widely produced with several models providing different capabilities of detection. The majority of detector cards that are available offer the following features: presence or pulse mode, frequency levels, levels of sensitivity, fail-safe operation, two- to four-channel output, and a channel disable. In addition, some companies make specialized detector cards that can differentiate between bicycles and vehicles. The specialized detector cards can provide additional green time to bicyclists while maintaining the minimum green time for vehicles. Additional considerations that can be programmed into the controller are extension times, gap out times, and more.

Sensitivity

For each frequency channel the detector card has, the level of sensitivity can be adjusted based on the number of sensitivity settings the particular detector card has. The sensitivity setting measures the ratio of the change in inductance when a vehicle occupies the loop to the level of inductance when a vehicle is not occupying the loop. Higher sensitivity settings will provide a call for a smaller change in inductance and may allow shared-lane vehicular loops to detect the presence of bicyclists more easily; however, higher sensitivities may also trigger false positives from vehicles in adjacent lanes. Multiple adjustments may be necessary to find a level that detects bicyclists without generating numerous false positives. It is recommended to test the detector's ability to recognize an actual bike by using an aluminum or carbon fiber bike to ensure a wider variety of different bike types will be detected.

Pulse vs. Presence

When choosing which application to use, it is important to understand the purpose of the detector. Detector cards have two types of detection settings; presence mode and pulse mode.

Pulse detection is a setting where the loop will maintain a "pulse" in inductance from the entering vehicle for a given number of milliseconds (typically 125 milliseconds). If a vehicle remains on the loop for more than two seconds, the call is dropped. The pulse detection setting is commonly used on upstream detectors that are providing advanced detection or acting as a count station, and on loops that are monitoring speed.

Presence detection is a setting in which the loop will maintain a call while a vehicle occupies the loop. This application is typically used for stop bar detection. An additional setting in the controller is whether to apply a locking memory vs. non-locking memory for the loop. Locking memory will maintain a vehicle call on that channel, even if the vehicle pulls off of the loop. The call will be dropped once that phase is served. This application is typically used with left-turn lanes and side street through movements. Non-locking memory is the opposite. If the vehicle moves off of the loop, the call is dropped. Non-locking memory is typically used in shared thru/right turn lanes where a vehicle may turn right and is no longer waiting to be served.

Detector Card Settings

In addition to installing the correct pattern type and location for bicyclists to be detected, a few capabilities on the detector card need to be adjusted to produce the desired detection at stop bars. The following are a few items to check on the detector card:

- Presence mode (stop bar detection) or Pulse mode (upstream detection or count station)
- Set the frequency to a higher channel
- Set the sensitivity at 6 (FHWA, 2006)
- Verify the detector functions appropriately

Push Buttons

Controller Compatibility	High
Installation Complexity	Moderate to High
Functionality	Presence (Yes) Counts (No) Directionality (Yes) Distinguish Multiple Bikes (No)
Durability	Risk of vehicle collision depending on placement
Ideal Applications	For bicycle queuing spaces that provide convenient access to the button and active participation in calling the signal is desired

Strengths

- Low cost
- Reliable
- Low likelihood of false calls
- Ensures safety in that activation requires stopped condition
- Advanced models can provide audible and visual feedback to the user
- Use of push button leaves no question as to whether or not the bicyclist has been detected
- Advanced models can be real-time monitored for systems faults
- Not impacted by atmospheric weather conditions
- Ease of installation

Weaknesses

- Generally not suitable for bike lanes not adjacent to the curb line
- Not appropriate for approaches with right turn lanes without special design considerations
- Push button pole location can be prone to vehicular impact
- Consistent actuation relies on user compliance, which could be affected by aversion to communicable disease

- Motorists may attempt to use the button in some cases if utilizing it can allow them to exploit a gap in traffic.
- Application of extended green time for bicyclists is not as practical as other forms of detection, as users would not expect to stop for actuation during a green interval

Overview

Push buttons are mechanical user-activated devices commonly utilized to provide actuation of intervals for pedestrian movements at signalized intersections or mid-block crossings. Given certain circumstances, these same devices can be deployed for bicyclist actuation of signalized vehicular movements or warning beacons. If used within the street, the streetscape must allow for the push button to be located so that bicyclists can reach the push button and activate the signal without dismounting (NACTO).

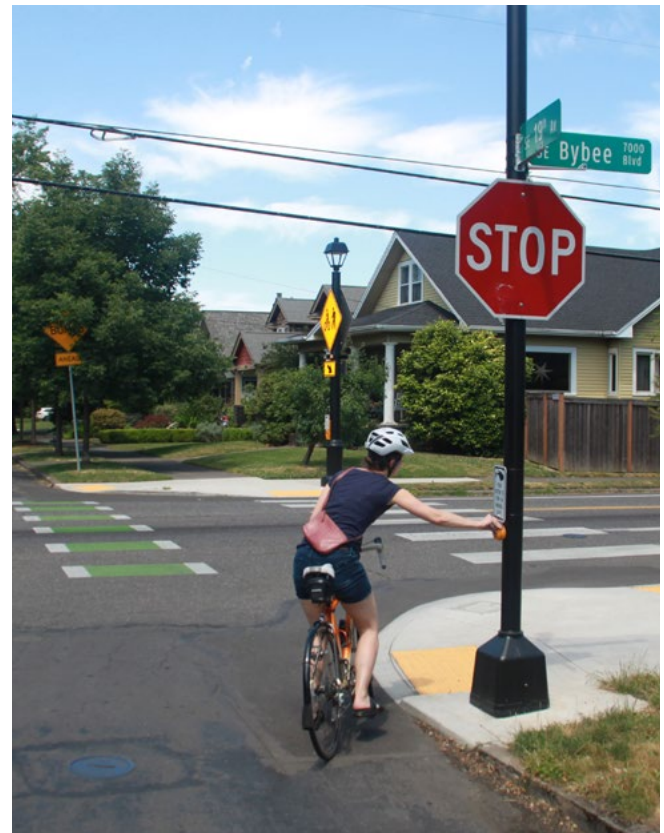

Push buttons should be easy to reach without dismounting

Common Applications

Bike push buttons may be preferable in certain situations in which bicycle actuation is desired and extension of green time is determined to not be necessary. Push buttons have a distinction in that they are “active” to the user, requiring the bicyclist to give a level of attention to being detected at the intersection, which differs from other passive forms of detection. Because buttons should be located such that bicyclists can reach them without dismounting, many streetscapes (such as those with the bike lane configured away from the curb) are not preferable for application of a bike push button. Push buttons are the most ideal when installed in an area protected from potential vehicle encroachment. Generally, push buttons do not work well for bike boxes and two-stage turn queue boxes, unless the queue box is configured as a jug handle within the streetscape. Bike push buttons can also be a relatively cheap, reliable, and easy-to-install device to “retrofit” an existing intersection in which other forms of detection have proven to be problematic.

The type of detection that a bicycle push button provides would typically be limited to presence detection with locking memory. This is not due to operational limitations of push button devices, but rather due to the physical requirements of push button actuation (stopping the bike, reaching over to the button). The physical necessities of push button actuation also impede the ability to accurately provide counts or monitor speeds. Because of these considerations, more often than at typical intersections, bicycle push buttons are applied at shared-use path mid-block crossings or other special intersections (e.g., Hybrid Beacon, Bicycle Signal, Toucan, RRFB) in which bicycles do not share signal indications with other vehicular movements and must actuate the crossing phase each time. Because of this, bike push buttons work well along low-volume minor streets where they cross major streets.



This push button has been extended to make it more accessible (credit: City of Fort Collins)



This same location has seen rare use by vehicles (credit: Joe Olson)

Installation Considerations

The installation of bicycle push buttons requires the installation of pedestal posts adjacent to the roadway and/or bikeway. While these pedestal posts typically require the installation of a concrete foundation, the construction of the pedestal posts is not considerably labor-intensive and requires only minimal disruption to traffic, if any. The specified location of a bike push button pedestal should take into account any existing or proposed features of the roadway, and avoid or address conflicts that may arise. In particular, bike push buttons should avoid close proximity to drainage inlet sumps to avoid bicyclist discomfort and safety issues. Extension devices can be installed to put the button in a more convenient position in some cases.

Push button pedestal assemblies that communicate wirelessly are currently available. However, due to reliability and familiarity of installation, wired push buttons are still commonly connected back to a central traffic signal controller. Therefore, it is generally recommended that the feasibility and cost of installation of cable and conduit be considered when specifying bicycle push buttons.

Like inductance loops, the actuation of a push button has the ability to communicate with detector cards compatible with all NEMA standard cabinets and controllers. In a bicycle push button installation at a typical intersection, detection cards associated with bicycle use would typically be wired to vehicular phases and adjusted for signal timing most appropriate for bicyclists.

KEY TIPS

Consider whether vehicles may abuse the presence of the push button and actuate it to gain a gap in traffic if used for a bicycle-specific crossing phase.

Push buttons can only measure presence of a stopped bicyclist and work best along minor street approaches or at trail crossings where the approach is always actuated. For projects where calling a signal phase for bicyclists along a major street is desired, a different type of detector that can provide advanced detection may be preferable.



This push button activates a bicycle signal along a separated bike lane in Eugene, OR



Separate push buttons are typically provided for pedestrians and bicyclists if users have adjacent crossing paths (Tucson, AZ)

ADDITIONAL TECHNICAL DETAIL

Design and Product Specification Considerations

With the only physical requirement of a bicycle push button being that it be located such that a bicyclist does not have to dismount to activate, the designer has some flexibility in how the push button is specified. Bicycle push buttons are commonly mounted similarly to pedestrian push buttons. Pedestrian push buttons are guided by ADA requirements, with a 42-inch push button height and proximity within 10 inches of the curb line. While push buttons with accessible pedestrian signal (APS) capabilities are specified for pedestrian push buttons in order to meet Public Rights-of-Way Accessibility Guidelines (PROWAG) requirements, accessible signal warnings are not required for bicycle movements. However, today's APS push button devices may be desirable as a bicycle push button due to their ability to enhance safety by providing visual and audible feedback to the user. Modern APS push button devices also have the advantage of the ability to be real-time monitored for maintenance. Push buttons that are specifically designed for bicycles and not necessarily designed for ADA-compliance can also be specified. These types of push buttons are generally designed for ease of use by the bicyclist, with the basic principle being that a larger push pad is easier to activate as compared to a button.

Signage Considerations

It is recommended that the inclusion of bicycle push buttons include supplementary signage to provide a clear direction to bicyclists what is expected for signal actuation. The MUTCD, Part 9, offers suggested guidance on supplementary regulatory signage that should accompany a bike push button. Where bicyclists are not intended to be controlled by pedestrian signal indications, an R10-4, R10-24, or R10-26 can be used to supplement the push button. The R10-24 and R10-26 both feature a bicycle stencil to provide a clearer indication that a particular push button is intended for bicyclists. If bicyclists are crossing at locations where warning lights or beacons have been installed, an R10-25 sign may be used. These signs are recommended to be mounted directly above the bike push button. The California MUTCD specifies an appropriate sign, R62C, that is similar to R10-26.



R10-24

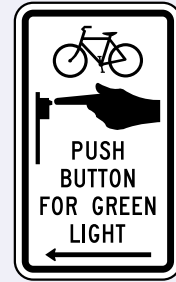

R10-26



R10-25



R10-4



Modification of R10-4 to be applicable to a bicycle signal

Microwave/Radar

Controller Compatibility	High
Installation Complexity	Moderate to High
Functionality	Presence (Yes) Counts (Yes) Directionality (Yes) Distinguish Multiple Bikes (No)
Durability	Good
Ideal Applications	Where advanced detection is desired or where the ability to differentiate direction of travel is important.

Strengths

- Used for both vehicles and bikes
- Provides actuation regardless of metal content in bike
- Can provide bike counts from dedicated or shared-use lanes (with specific equipment configuration)
- Can perform advanced and stop bar detection in a single unit
- Does not require pavement disruption
- Can be easily reconfigured to adapt to changes in the intersection
- Can distinguish between bikes and other vehicles
- Troubleshooting can typically occur outside of roadway limits
- Typically insensitive to inclement weather, glare, or low light conditions

Weaknesses

- Can have issues when placed in close proximity to large steel structures (e.g., steel bridges)
- Can have issues with overhead conductors within a microwave radar device's field of view
- Proper operation relies on proper field interpretation and set-up of detection zones
- Complexity associated with communication from multiple detection zones to central unit can impact reliability
- As compared to video, more difficult to confirm aim of detection optics and, thereby, troubleshoot

Overview

Microwave radar devices are used in several different traffic applications. In general, these devices detect traffic by transmitting microwave energy toward the roadway and measure the return signal reflected from vehicles on the approach. While CW (Continuous Wave) Doppler radar can only detect flow and speed, FMCW (Frequency Modulated Continuous Wave) radar can also act as a presence detector. As such, this discussion will focus on microwave FMCW radar detection systems. At an intersection, a microwave radar detection system typically consists of one or more FMCW radar devices and a cabinet interface module to process the feedback data from the devices and communicate with the traffic signal controller. In terms of bicycle detection, microwave radar detection systems need to have bicyclist approaches within the FMCW radar device's field of view.

Common Applications

Microwave radar detection is a good option for signalized intersections at which the installation of loops would not be practical and at which the installation of other common forms of detection, such as video, are determined to be problematic due to weather, low light, occlusion, or other factors. The range of some microwave radar detection devices allows for them to be used as both presence and advance detection, making them a cost-effective option for some intersections. Many microwave radar detection devices are capable of collecting counts, speed, distance, and classification data, with advances in detection software providing the ability to differentiate between bicycles and other vehicles. Signal timing modifications such as time extensions can be added when bicyclists are detected.

At signalized intersections, these devices provide the most benefit when mounted to traffic signal poles or mast arms such that the device is high enough to detect multiple detection zones. As such, microwave radar systems can vary in their cost-effectiveness due to the need to provide additional mounting structures necessary for roadway geometry or the lack of existing tall traffic signal infrastructure or signal mast arms. When exploring the potential use of this detection at a particular intersection, designers should consider the desired functionality of the detection system and the required placement of microwave radar devices. Because these devices provide a 90-degree



This microwave detector in along the Razorback Greenway in Northwest Arkansas activates a warning beacon when a trail user (pedestrian or bicyclist) is approaching the roadway crossing.

field-of-view, they have some flexibility to be mounted outside of the roadway limits. The functionality of these devices, however, can be affected by the presence of large steel structures (such as steel trusses associated with bridges) or overhead conductors. Therefore, in-person reviews are strongly recommended to determine the suitability of a particular site for the implementation of a microwave radar detection system. It typically can be helpful to confirm the feasibility of microwave radar device placement with a manufacturer's representative.

Microwave radar detection systems can also be used at bicycle-specific approaches or shared-use path mid-block crossings. In these cases, the microwave radar devices can offer passive actuation of signalized crossings for both bicyclists and pedestrians. Detection of these movements does not typically require the greater mounting heights that are advantageous for vehicular movements. As such, in these types of applications, cameras can be mounted to pedestal signal or beacon posts, as long as security of the radar equipment is ensured. These detection systems have also been "retrofit" installed for similar situations in which the push button use compliance rate was found to not be satisfactory.

Installation Considerations

Any installation using a signal mast would require lane closure for operation of a bucket truck, with those installations to the mast arms likely requiring a greater disturbance to vehicular traffic. These devices are sometimes mounted to luminaire mast arms to provide an even greater mounting height. For bicycle-specific detectors, they do not need to be mounted as high and can be attached to poles. Manufacturers typically provide recommended mounting heights for the radar devices, based on the device's offset from the first detection lane. Many manufacturers recommend mounting the devices as close to perpendicular to the flow of traffic as possible. For this reason, these devices are commonly mounted on the vertical portion of the nearside traffic signal post, rather than the far side mast arm, as is commonly specified with video detection cameras. The radar devices typically are mounted with a horizontal extension bracket that allows for the device to be tilted and aimed toward the center of the detection area.

Typical microwave radar detection systems are capable of connecting four sensors to one cabinet interface module. Systems vary, but most microwave radar sensors are capable of supporting up to eight detection zones. Communication with and data transmission between

the sensors and the cabinet interface module is typically achieved by running cable either aerially or through the traffic signal infrastructure and the underground pull box/ conduit runs used for traffic signal conductor cables. The sensor units generally require low power consumption, and can draw power either through a wired connection to a power source, or from properly-rated solar panels.



This microwave detector in Huntsville, AL, calls the bicycle signal only for approaching bicyclists who are within the separated bike lane. Microwave detectors can determine if the bicyclist is approaching or moving away from the intersection to avoid false calls.

KEY TIPS

Radar can be set to only detect above a certain approach speed which could be used to distinguish between bicyclists and pedestrians. Studies conducted in California found that high speed bicyclists might sometimes be classified as vehicles. Similarly, groups of bicyclists were sometimes classified as vehicles.

Occlusion can occur if placed incorrectly to detect bicyclists. Be wary of placing the unit where a heavy vehicle may block the units ability to detect a bicyclist.

Use as Counter

Microwave sensors are a popular technology used to detect and count bicyclists and pedestrians. There are many commercially available products that have a variety of strengths. Some are designed specifically for shared-use paths, while some may also work in bike lanes or shared lanes. Depending on the product, the device may be able to count bicyclists and pedestrians separately, together, or be configured to omit one or the other. Devices used solely as counters are typically mounted at low height (two to five feet above ground level). Equipment should be secured so that it is not vandalized or removed.

Data can be collected continuously and downloaded via a physical connection or wirelessly through the internet using a SIM card connected to the cellular network. Alta has a companion white paper entitled [“Innovation in Bicycle and Pedestrian Counts”](#) available on our website (www.altago.com).



This microwave automated counter counts the volume of pedestrians and bicyclists accessing this rail station in Oakland, CA

ADDITIONAL TECHNICAL DETAIL

Design and Product Specification Considerations

Microwave radar detection systems typically are equipped with management software used to correct the sensor installation and fine-tune sensor alignment. These software applications are typically run through a field computer that interfaces with the cabinet interface module (detection card). Cabinet interface modules associated with microwave radar detection systems are compatible with standard NEMA cabinets and controllers. Many maintenance and adjustment activities required for an active infrared detection system can take place from within the controller cabinet using the computer interface.

Additional Standards

Various industry standards have been developed for the purpose of specifying microwave radar detection systems. Such industry standards include, but are not limited to, those associated with:

- National Transportation Communication for ITS Protocol (NTCIP)
- National Electrical Manufacturer Association (NEMA)
- National Electric Safety Code (NESC)
- National Fire Protection Association (NFPA) 70 – National Electric Code
- National Fire Protection Association (NFPA) 780 – Standard for the Installation of Lightning Protection Systems
- Underwriter Laboratories (UL) Standards – 96 & 96A Lightning Protection
- Underwriter Laboratories (UL) Standards – 1449 Surge Protective Devices

Communication equipment and software associated with microwave radar detection systems can also be subject to Telecommunication Industry Association (TIA) 232 standards and Federal Communications Commission (FCC) certification requirements. Some agencies have considered these industry standards in developing approved product lists for these systems, and, as such, manufacture of these systems has become fairly standardized. However, it is important to consider that some approved product lists may have been developed without consideration of active transportation needs. As such, designers should verify that the capabilities and functionality of an agency's approved products are consistent with the goals of a given project, particularly with respect to a unit's ability to distinguish between bikes and other vehicles, and the ability to provide bike counts.

Video

Controller Compatibility	Low to Moderate
Installation Complexity	Moderate to High
Functionality	Presence (Yes) Counts (Yes) Directionality (Yes) Distinguish Multiple Bikes (Yes)
Durability	Good
Ideal Applications	Most bicycle oriented scenarios

Strengths

- Used for both vehicles and bicyclists
- Provides actuation regardless of metal content in bike
- Can distinguish between bikes and other vehicles
- Can supplement other forms of detection in use at an intersection
- Can distinguish multiple bicycles on an approach
- Can be configured to count bicyclists in dedicated or shared-use lanes (though accuracy has historically not been consistent)
- Can be easily reconfigured to adapt to changes in the intersection
- Does not require work within the roadway limits to install; however, camera installation may require temporary lane closures
- Troubleshooting can typically occur outside of roadway limits

Weaknesses

- Initial installation costs can be relatively high
- Complexity associated with communication from multiple video zones to central unit can impact reliability
- Proper operation relies on proper field interpretation and set-up of detection zones
- Accuracy can be affected by weather conditions, including rain, snow, fog, sun glare, shadows, and day-to-night transitions

- Accuracy can be affected by vehicle/road contrast and other visual obstructions, such as dirt, salt, cobwebs, or span wires and aerial utilities within the field of view
- Detection zones can pick up false activations from adjacent lanes if configured improperly
- Some communities can be sensitive to privacy concerns

Overview

In modern traffic management applications, video detection systems use video image processing to determine when to place signal calls. A video detection system typically consists of one or more cameras, a microprocessor to process the imagery, and software to interpret the traffic flow data and communicate with the traffic signal controller. In general, video detection systems can determine vehicle arrivals by analyzing successive video frames. Modern video detection systems can also extract a significant amount of data through the associated video image processor (VIP). The VIP often consists of a microprocessor on a detection card/board that is compatible with standard NEMA cabinets and controllers. In terms of bicycle detection, video detection systems feature cameras aimed at bicyclist approaches and software calibrated to detect the smaller vehicle size associated with bicyclists.

Common Applications

Video detection is a good option for signalized intersections at which the installation of loops would not be practical due to the existing pavement condition or structural composition, or due to right-of-way or jurisdictional issues. Many agencies are moving completely to video or thermal detection for all intersections, with many establishing Traffic Management Centers (TMCs) that can monitor the entire network remotely. Video detection systems are typically mounted to traffic signal poles, mast arms, and luminaries such that the camera lens has a suitable vantage point to clearly observe as many detection zones as possible. In some instances, it can be helpful to confirm the feasibility of potential camera placement with a manufacturer's representative.

In shared lane contexts, bicyclists can be distinguished from vehicles with recent advances in detection software. Separate detection zones can also be set up for

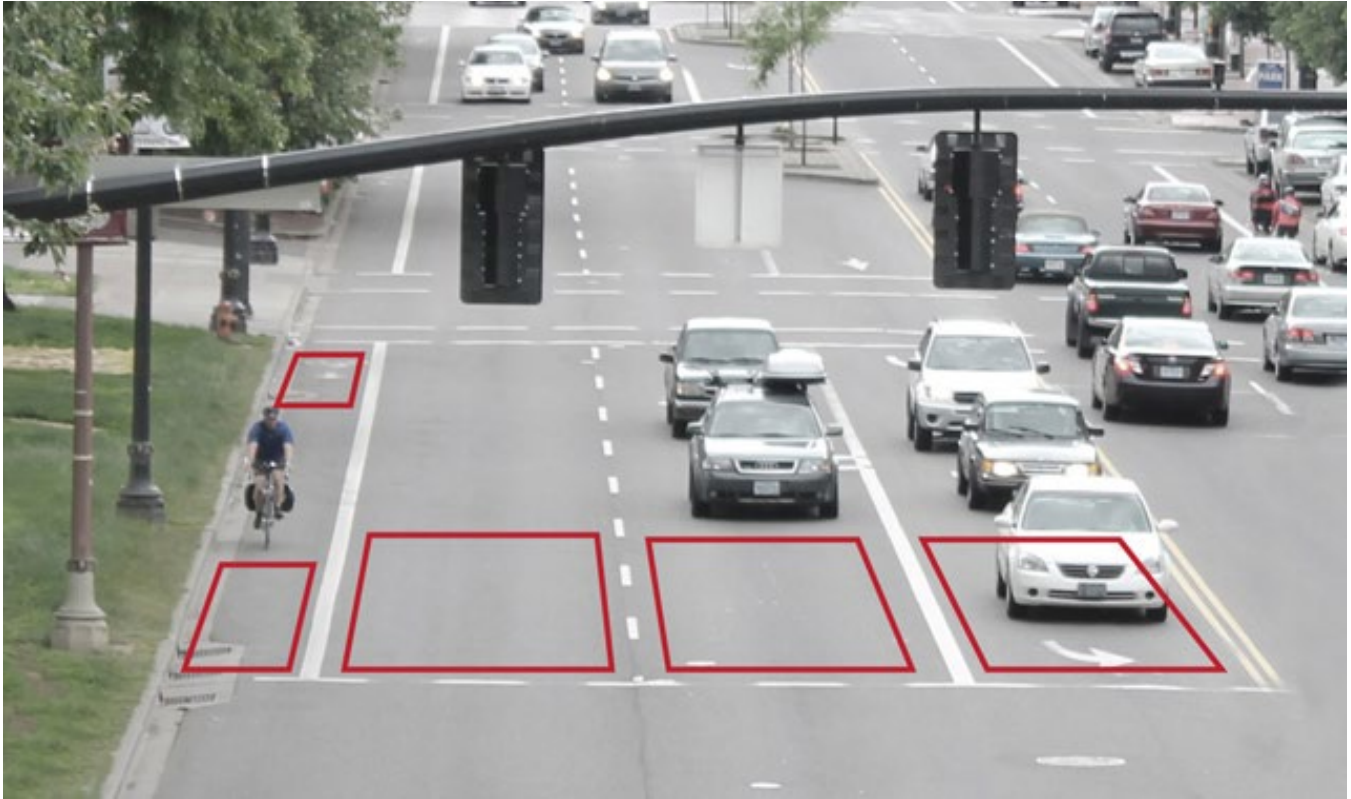

This image represents a still taken from a video camera showing the detection zones in red (credit: NACTO)

bicycle-only facilities. In either case, counts or signal timing modifications such as time extensions can be added when bicyclists are detected.

For bicycle-specific approaches, video cameras can be mounted lower. As such, in these types of applications, cameras can be mounted to pedestal signal or beacon posts, as long as security of the camera equipment is assured. Video detection systems have been “retrofit” installed for similar situations in which the push button use compliance rate was found to not be satisfactory.

In general, modern video detection systems offer a great deal of flexibility in how they interpret vehicle arrivals and how they interface with traffic signal controller software. Advances in camera technology have significantly improved upon issues with reliability associated with older camera models. Similarly, software is updated regularly and can improve accuracy and functionality if kept current. Agencies should ensure that video detection systems in use and listed as qualified products for installation are consistent with the expected capabilities.

Installation Considerations

Camera equipment associated with video detection systems is typically mounted on mast arms over the roadway, and, therefore, requires lane closure for operation of a bucket truck. These cameras are often mounted to a vertical extension bracket that positions the camera above the mast arm to maximize mounting height. The cameras are sometimes mounted to luminaire mast arms in order to provide an even greater mounting height. For vehicular traffic approaches, the FHWA recommends a minimum camera mounting height of 40 feet above the detection area if the camera is centered over the roadway. Higher mounting heights (on the order of 50 feet or greater) are recommended if the camera is located at the side of a roadway. The camera mounting height should increase as the camera is moved further from the road edge to achieve optimal performance. The camera location should minimize occlusion of down-lane and cross-lane vehicles. Down-lane occlusion refers to a vehicle blocked from view by a tall vehicle in front of it. Cross-lane occlusion refers to a vehicle blocked from view by a tall vehicle in a lane



This camera in Missouri has been raised in elevation to obtain a better view of the intersection and its detection zones

KEY TIPS

Video detection can be very flexible in changing intersection configurations.

Single camera systems that operate with a “fish eye” view of the intersection may not be as accurate for bicycle detection as multiple camera systems. The City of Austin has added supplemental bicycle specific video cameras for bike approaches, which adds expense.

Many existing video-based detection systems can have the ability to detect and count bicyclists added for low or no cost through manufacturer software and firmware updates.

closer to the camera. Due to this need, specific camera locations typically must be determined in the field while simultaneously viewing the video feedback.

Camera locations should typically be chosen such that vibration and motion is minimized. However, some modern models have the ability to stabilize imagery and are designed for span wire mounting if more stable mounting cannot be achieved. In general, cameras often require a downward tilt or the installation of a sunshield to prevent glare from the horizon. Camera locations must also attempt to minimize glare from headlights and reflections from the pavement, which can sometimes be mitigated by the use of a longer focal lens length. Infrared (or thermal) cameras, covered in the next section, overcome many of these disadvantages.

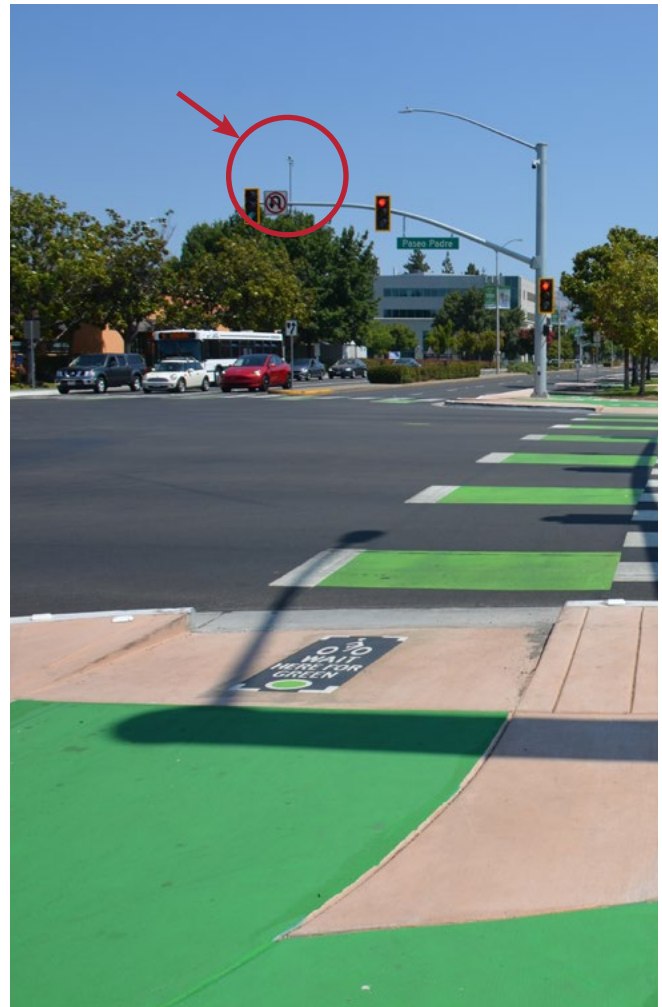

Video detection is being used at this protected intersection in Fremont, CA

ADDITIONAL TECHNICAL DETAIL

Further Installation Guidance

The focal length of the camera lens is dependent on the mounting height of the camera, the local topography, distance to the nearest detection area, and the width of the detection area. The resulting horizontal and vertical fields of view correspond to a required focal length. If the required focal length does not correspond to a standard lens, then the mounting height or one of the detection area parameters is varied in order to allow specification of a standard lens having a horizontal focal length above or below that of the initial calculation. Many modern cameras associated with video detection systems have variable focal length lenses available, so that a specific lens does not have to be identified in advance.

Upon mounting the camera, transmission of the video imagery to the VIP must be accomplished. Although wireless video detection systems are available, this is typically achieved by running cable for power, control, and data transmission to and from each camera. Like push buttons or other actuation devices, the wireless systems are generally viewed as less reliable. Communication with the VIP (located in the controller cabinet) can be achieved by running cable aerially or through the traffic signal infrastructure and the underground pull box/conduit runs used for traffic signal conductor cables. Once video imagery is transmitted to the VIP, operating parameters should be established, detection zones on the roadway should be defined, and the image area calibrated. Most video detection systems are provided with setup and calibration software that can be operated on a personal computer that interfaces with the VIP. Detection zones can be calibrated to gather vehicle presence, counts, speed, lane occupancy, and vehicle length classification data. VIP devices also typically provide the ability to program special operational conditions for connecting detection zone outputs, which can be useful in ensuring more accurate actuation and vehicle counts. The detection zones are typically drawn onto the camera's field of view using the computer monitor interface. Multiple detection zones can be drawn within the field of view of each camera.

Calibration

Calibration of the image area requires that several pieces of data be provided to the VIP. This typically involves defining the lens focal length, the CD array size, the dimension of the image area (along-lane and cross-lane dimensions), the number of lanes, distance between two defined points in the image, the external communication rate, the camera output voltage, date, time of day, and traffic flow direction. Calibration can also require inputting the camera's horizontal and vertical angle, camera height, camera offset from the traffic flow, the typical traffic flow rate, lane occupancy, speed, headway, vehicle length, distance to detection zone, and length of detection zone. The microprocessor associated with the VIP sends processed presence data received from the cameras directly to the traffic signal controller via cable-connected outputs.

The majority of maintenance and adjustments required for a video detection system can take place from within the controller cabinet using a computer interface. However, maintenance of video detection systems can occasionally require lane closures to address storm damage or general "wear and tear" to cameras mounted on mast arms, or to clean the associated lenses.

Infrared

Controller Compatibility	Low to Moderate
Installation Complexity	Moderate to High
Functionality	Presence (Yes) Counts (Yes) Directionality (Yes) Distinguish Multiple Bikes (Yes)
Durability	Good
Ideal Applications	Most bicycle oriented scenarios

Strengths

- Used for both vehicles and bicyclists
- Does not have weaknesses of video detection as it can see through fog, snow, and direct sunlight or shadow
- Provides actuation regardless of metal content in bike
- Can distinguish between bikes and other vehicles
- Can supplement other forms of detection in use at an intersection
- Can distinguish multiple bicycles on an approach
- Can be configured to count bicyclists from dedicated or shared-use lanes (though accuracy has historically not been consistent)
- Can be easily reconfigured to adapt to changes in the intersection
- Does not require work within the roadway limits to install; however, camera installation may require temporary lane closures
- Troubleshooting can typically occur outside of roadway limits

Weaknesses

- Initial installation costs can be relatively high
- Complexity associated with communication from multiple video zones to central unit can impact reliability
- Proper operation relies on proper field interpretation and set-up of detection zones
- Detection zones can pick up false activations from adjacent lanes if configured improperly

Overview

In terms of modern vehicular detection at intersections, infrared technology is commonly deployed in conjunction with the video detection systems discussed in the previous section. Infrared video detection systems, also referred to as thermal video detection systems, are an increasingly popular method of addressing common issues associated with traditional video detection systems, such as weather or time-of-day glare. In general, the sensors associated with these detection systems use thermal imaging to detect oncoming vehicles. Because these systems rely on the heat signature associated with vehicles or bicyclists, they are unaffected by line-of-sight issues associated with traditional video cameras. Infrared detection systems typically consist of one or more thermal cameras, a microprocessor to process the thermal imagery, and software to interpret the traffic flow data and communicate with the traffic signal controller. These systems are typically able to extract a significant amount of data from the thermal imagery.

Common Applications

Infrared detection systems are commonly installed for intersections at which existing video detection systems have proven to be problematic due to various issues. Video detection systems can commonly be affected by weather, time-of-day glare, or other visual obstructions. With the use of infrared video detection systems becoming more common, some agencies are anticipating potential issues with traditional video detection systems and opting for specification of thermal cameras with the construction of new traffic signals. Modern manufacturers of traditional video detection systems are commonly making available an infrared video detection option, or even dual camera systems which feature both technologies. In many instances, an in-person review with a manufacturer's representative can be helpful to confirm whether an infrared detection system would be a cost-effective solution to address potential issues with a traditional video detection system.

Infrared detection systems can also be applied at shared-use path mid-block crossings or other special intersections in a similar manner as discussed for push button actuation. In these applications, thermal cameras can be mounted on nearby traffic signal pedestal posts. These can be installed for locations in which the push

button use compliance rate is found to not be satisfactory. It should be ensured that thermal cameras specified for these types of applications are secure. Placement of the sensors should also be such that they are not activated by vehicles traveling on the main roadway.

Installation Considerations

At typical signalized intersections, thermal cameras can be mounted to traffic signal mast arms in a similar manner as was discussed with the video detection systems. Therefore, installation typically requires lane closure for operation of a bucket truck. As with traditional video detection systems, the thermal cameras associated with infrared detection systems can offer greater benefit, as the camera's mounting height provides coverage of more detection zones. The mounting height of the thermal device should increase as it is moved further from the road edge to achieve optimal performance. When compared to traditional video detection systems, vehicular occlusion, vegetation, overhead utility lines, or other visual obstructions can be significantly less of a consideration in determining the



"Alta" is being spelled out with the body heat of staff members from our Seattle, WA office

specific location of the thermal camera. Despite this, these thermal devices are typically capable of providing video feedback to the installer to verify the device's range of view. Locations for the thermal cameras should typically be chosen such that vibration and motion is minimized.

ADDITIONAL TECHNICAL DETAIL

Further Installation Guidance

Although wireless infrared detection systems are available, power, control, and data transmission are typically achieved by running cable from each thermal camera to a detector card with a microprocessor. Cable can be run aerially or through the traffic signal infrastructure and the underground pull box/conduit runs used for traffic signal conductor cables. The detection operating parameters can typically be operated from a personal computer that interfaces with the detection card. Like the video detection

KEY TIPS

For applications where pavement temperature frequently hovers in the high 90s, the contrast between body temperature and surface temperature may not be high enough for reliable detection.

calibration process, typical operating parameter inputs for the calibration of detection zones include the number of lanes, the typical traffic flow rate, lane occupancy, speed, headway, vehicle length, date, and time of day. Since thermal cameras offer the ability to make a reliable distinction between bicycles, pedestrians, and vehicles, bike-specific signal timing can be programmed to occur when bicycles are detected.

Detection cards associated with infrared detection systems are compatible with standard NEMA cabinets and controllers. The microprocessor in the detection cards sends processed presence data directly to the traffic signal controller via cable-connected outputs. Many maintenance and adjustment activities required for an infrared detection system can take place from within the controller cabinet using a computer interface. However, maintenance of the thermal cameras can occasionally require lane closures to address damage or general "wear and tear" to the overhead devices.

In-Ground Radar

Controller Compatibility	High
Installation Complexity	Moderate to High
Functionality	Presence (Yes) Counts (Yes) Directionality (Yes) Distinguish Multiple Bikes (No)
Durability	Battery life: eight to ten years
Ideal Applications	Technology supports most application by may be particularly useful in separated bike lanes or areas with bicyclists as the only user group

Strengths

- Used for both vehicles and bikes
- Provides bike counts when applied to dedicated bike lanes
- Not impacted by rain, fog, glare, or ambient light levels
- Provides actuation regardless of metal content in bike
- Ease of installation
- Can distinguish between bikes and vehicles stopped at the stop bar, enabling more efficient signal timing
- Can remain in place and function during and after resurfacing
- Installs in less time than loops
- Can supplement other forms of detection in use at an intersection

Weaknesses

- Installation and maintenance requires temporary lane closures
- Complexity associated with communication from array of wireless detectors to central unit can impact reliability
- Life cycle cost includes battery maintenance responsibility
- Can pick up false activations from adjacent lanes
- Performance diminishes in standing water or in slushy conditions

Overview

In-ground radar generally consists of compact radar sensors that are installed just beneath the roadway surface. These sensors generally incorporate low power, wide-band radar with radio communications. In order to measure presence, these devices require the use of frequency-modulated continuous-wave radar, which transmits high frequency pulses that can “bounce” off target objects, returning pulses that are measured by the device. The size of these radio frequency “reflections” helps the in-ground radar device interpret and distinguish between cars, trucks, and bicycles. These devices have the capability to detect and differentiate between all vehicles (bikes, cars, trucks) in motion within a programmable detection range.

Common Applications

In-ground radar can be advantageous for bike detection in situations in which other forms of detection have operational concerns. In particular, concerns with loop detection’s ability to detect bikes with low amounts of metal, or concerns with glare/visibility that can affect video detection, can be mitigated by use of in-ground radar. Wireless traffic sensors associated with in-ground radar are most commonly installed as presence detectors at stop bars, but can also be installed to serve as advance detection. These wireless traffic sensors can also be an advantageous option to supplement or enhance detection for situations in which little construction impact is desired at an existing intersection. Installation of in-ground radar could also be considered where bike count data is desired for bike lanes or bikeways. Several cities including San Francisco, Seattle, Washington DC and Buffalo have made expansive use of the technology.

Installation Considerations

The traffic sensors associated with in-ground radar are installed from the road surface in the lane in which detection is desired. Installation generally requires a four-inch-diameter hole drilled in the center of the desired travel lane. For bicycles, these installations are typically located just in advance of the stop bar. The devices are installed such that the top of the device is flush to the roadway surface. These devices generally have the ability to detect a bicycle once it’s within eight feet of the sensor device. Once placement and activation of the device is



Installation includes (1) coring out a hole in the pavement, (2) placing the sensor, and (3) backfilling with epoxy

confirmed, the traffic sensor is covered with a fast-drying epoxy. The installation of the traffic sensors should only require minimal lane closure time, with no saw cutting of the pavement required.

In order to provide full vehicle classification capabilities, it is generally recommended that at least two in-ground radar devices be installed in each lane requiring detection. These are recommended to be spaced 12 to 15 feet apart. In bike lanes, a single in-ground radar device installed at the stop bar is sufficient to provide presence detection. An additional device can be included in locations that warrant advance detection.

Agencies installing in-ground radar systems should be cognizant that each traffic sensor unit is powered by independent batteries. While these units do not consume great amounts of power, the batteries that come with these devices generally have life cycles that generally range between eight to ten years. Batteries are replaceable within the devices, but removal and reapplication of epoxy must be performed. These batteries can be vulnerable to water, so the installation should ensure that the sensor units are protected from moisture.

In-ground radar systems generally require that serial port protocol (SPP) radios be installed within the traffic signal cabinets. These radios are compatible with NEMA standard

cabinets and controllers, and relay detection data to the traffic signal controller via a processing module. Processing modules associated with in-ground radar systems have the ability to interpret per-lane or per-vehicle data, bin data over selectable time intervals, filtering of data, and a platform for remote operations. The processing unit also allows sensor timestamps to be synchronized to NIST timing signals.

Other Considerations

Specification of in-ground radar should consider agency familiarity with the systems, as communication to and from the wireless devices differs from conventional traffic signal cabinet set-ups. As such, in-ground radar is sometimes applied to an existing intersection or corridor in a “scalable” manner, such that it supplements the existing detection system while providing agency familiarity to the system’s operations. This scalability of in-ground systems allows for the complexities of the systems to be more manageable through training.

KEY TIPS

Agency interviews regarding this technology applied to bicycle specific detection yielded mixed conclusions – some successful projects, with some unsuccessful. Recent years have seen the technology improve and it may become more reliable and cost-effective in time. With the successful project, battery replacement was seen as a negative.



In-ground radar installation patch in Lincoln, NE. Ultimately, this system was deactivated and the signals reverted to fixed timing.

Bicyclist App - Broadcast Presence

Controller Compatibility	Low
Installation Complexity	Moderate to High
Functionality	Presence (Yes) Counts (Yes - for those with app) Directionality (Yes) Distinguish Multiple Bikes (Yes - for those with app)
Durability	Unknown
Ideal Applications	Unknown; possibly where bicyclists are lower in number and tech savvy

Strengths

- Can detect bikes in advance of the intersection
- Can distinguish bicycles and initiate a bike phase or extend the green time for bicycles
- Can provide audible and visual feedback of detection to the user
- User can view traffic signal status within the application in approaching an intersection
- Some software apps allow for directional turn selection
- Some software apps can communicate with the same cabinet components used for transit or first-response vehicle priority
- Installation and maintenance occurs outside of roadway limits, fully preserving pavement condition
- Can provide bicycle count data for those using the app
- Provides actuation regardless of metal content in bike
- Can supplement other forms of detection in use at an intersection

Weaknesses

- Requires users to have foreknowledge, download the mobile application, and turn on Bluetooth or GPS capabilities
- Requires signals to be equipped with Bluetooth routers or 4G mobile networks
- Relatively new and needs further research

- Would not detect bicyclists if they were not using a smartphone and the software application; requires the signal to have a secondary means of detecting bicyclists
- Some communities might have privacy concerns with this technology
- Susceptible to periodic failures due to problems inherent with Bluetooth or cellular communication
- Results in added drain on mobile device battery if left active

Overview

Bicycle broadcasting through smartphone software applications are relatively new additions to bicycle detection. These bicycle detection app systems enable secure data communication between bicyclists and traffic signal controllers. These systems involve the installation of a detection input device within the controller cabinet that has the means to communicate with the traffic signal controller as well as with smartphone devices. These systems depend on bicyclists use of the required mobile software app, and ensure that the correct communication settings are established.

Common Applications

Because these systems are relatively new to the industry, common situations in which they could be applied have not been specifically identified. However, because of the heavy reliance on user education and the digital engagement of its users, these systems would be more easily implemented in areas that already see high levels of smartphone ownership and community engagement. These systems are unique in that they allow features which are not available in other forms of bicycle detection, including providing operational information to the user from an approaching traffic control device. As such, these systems could be considered in areas looking to enhance safety by improving bicyclist wayfinding and addressing intersections with visibility limitations. For agencies looking to engage in more connected vehicle applications in the future, this detection software can be a way of introducing this technology to a community and to signal maintenance personnel.

In the few areas where these systems have been implemented as pilot projects, agencies have augmented with video cameras, radar, or detection loops to ensure that

bicyclists without smartphones, without the associated software application, or whose smartphone battery is exhausted, are still detected. In order for these systems to become a cost-effective alternative to other forms of bike detection systems, the compliance rate of users must be reliable enough so as not to require a supplementary form of detection, as is currently being practiced. As smartphone ownership becomes more ubiquitous in the future, the reliability, cost-effectiveness and, subsequently, the popularity of these systems will likely see an increase. Even without the assurance of smartphone compliance from the public, there are opportunities for this technology to be applied to non-smartphone devices. An inexpensive, solar-powered device that mounts to bike handlebars and performs the same duties as the smartphone application could become a standard accessory for bike owners, and could be built into new bikes.

Where bicyclist software application systems are considered, user education, including public meetings, newsletters, and press releases, should be considered as part of the implementation effort. Pilot projects have augmented these systems with blue feedback lights at the intersections, in order to mitigate situations in which a user may not have the smartphone device within the detector's field of view.

Installation Considerations

Two current systems utilize different communication methods. One system uses cellular networks to transmit location data to a central Traffic Management Center which then sends the information to the individual signal controllers. An alternate technology utilizes Bluetooth technology. Bluetooth systems can offer a level of security that systems that rely on GPS-determined locations can't typically provide. For these systems, a Bluetooth antenna would be mounted to a signal pole, on top of the traffic signal controller, or another secure location that allows communication with bicyclists on a particular approach. The antenna device is typically wired to detection module components inside the signal cabinet that communicate with the signal controller. Like other detection systems, the detection module components can be programmed to an agency's respective traffic signal management system using a computer interface. This computer interface can also be used to identify approaches and detection zones, as well as program a detection system to be presence-only

or provide green time extensions for bicyclists on the approach. Once a particular agency is satisfied with the installation, bicyclists would need to be made aware what steps need to be taken on their end to ensure detection. This typically consists of downloading the required mobile application and ensuring that the Bluetooth capability on their smartphone is turned on.



Austin's "Bicycle Mobility App" helps detect bikes at over 70 signalized intersections in the city. This system was deployed in 2015. Source: City of Austin via YouTube

KEY TIPS

The City of Santa Clarita, CA, has piloted the technology and feels that it has promise as a component of a future smart city application. Users have become aware of the need to turn the app on before approaching the intersection, but typically turn it back off after leaving the corridor. Draining smartphone batteries is a noted issue. As of 2021, Fort Wayne, IN, and Austin, TX, are both also piloting forms of the technology.



This pavement stencil indicates to bicyclists where they should wait to trigger the loop detector which activates a bicycle-only diagonal crossing. Pedestrians cannot activate the bike signal and must use the crosswalks and pedestrian signals. Photo credit: City of Missoula & Missoula MPO

04 ENHANCEMENTS

This section covers other technologies and innovations that impact or enhance bicyclist comprehension, improve signal compliance, and improve the accuracy of detection and special actuation of signals or beacons. These enhancements may be paired with a variety of bicycle facility types and with any of the detection methods detailed in this white paper.

Bicyclist Detector Pavement Markings

Many forms of bicycle detection, whether it be a loop, video, infrared, or in-ground radar, require a bicyclist to occupy a specific physical space to be detected. Microwave detectors are less dependent on users being in a specific location. A pavement marking has long been recognized as a valuable supplement to a bicyclists' understanding of traffic signal actuation at intersections with any type of detection that relies on the bicyclist being positioned in a set location. Detector pavement markings can be placed in shared travel lanes, bike boxes, separated bike lanes, behind the curb where raised facilities interact with intersections, and in many other contexts. The 2009 MUTCD provides a standard marking depicted in Figure 9C-7 with the R10-22 sign being recommended to accompany the bicycle detector pavement marking. The pavement marking should be located in the ideal place for a bicyclist to be detected when stopped at a traffic signal.



This 2009 edition MUTCD pavement detector marking is indicating to bicyclists where to wait in this shared lane so that they are on the most sensitive part of the Type E circular loop detector.

Figure 9C-7. Bicycle Detector Pavement Mark



During the 2010s, this detector marking and sign have been widely used across the United States with mixed success. One issue has been a lack of comprehension by the general public. This has led to a substantial amount of experimentation to create an alternative marking that improves bicyclist compliance. In recent years, there have been at least three studies that have evaluated the effectiveness of this standard MUTCD marking. A 2017 report to FHWA and the City of Columbia, MO, prepared by Alta Planning + Design evaluated four different pavement detector markings. The marking with the lowest comprehension by study participants was the current MUTCD symbol. Adding a green backing to the MUTCD symbol increased comprehension and visibility, but it is clear from the results that supplemental text instructing a bicyclist to wait over the symbol makes the marking more effective.

This 2009 MUTCD provides a detector marking pavement stencil and accompanying sign

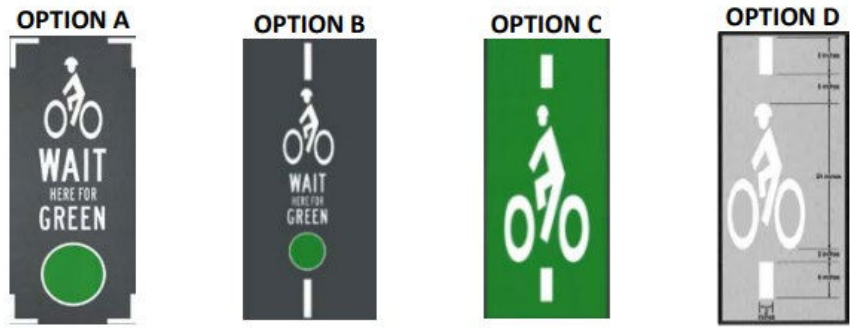

Symbol is visible	92.31%	69.23%	84.62%	44.0%
Symbol effective communicates purpose	96.15%	92.31%	50.0%	19.23%
Symbol is clear	92.31%	92.31%	46.15%	30.77%

Summary table from a FHWA experimentation study in Columbia, MO, completed in 2017 showing the effectiveness of the existing MUTCD stencil

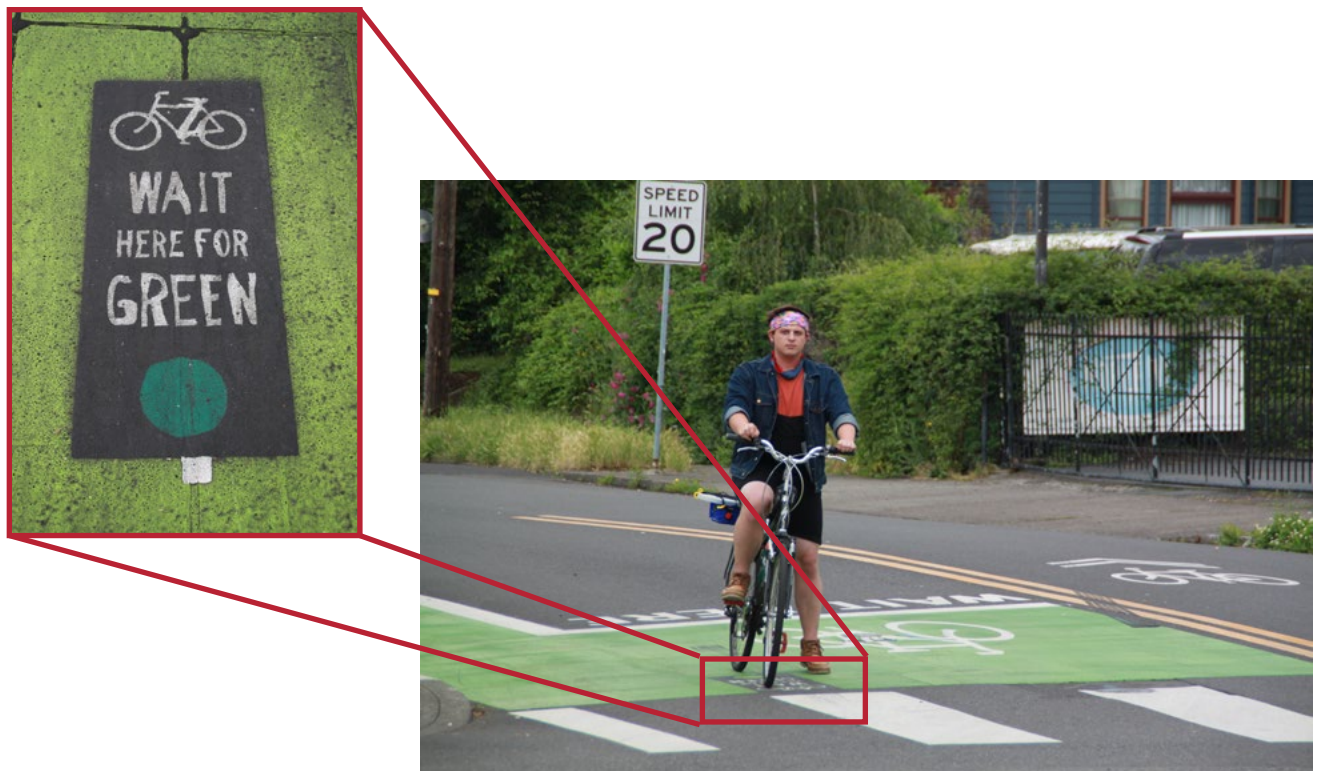

Research found that this modified pavement detector marking was more intuitive to understand by people biking

Also in 2017 a second study on bicycle detector pavement markings was also released in the ITE Journal. It used a marking similar to the preferred Columbia, MO, marking, shown below, and confirmed that the marking overall “appears to have the best potential for being intuitively understood by bicyclists.” The study also confirmed that any marking with text had higher levels of comprehension.

In 2018, the National Committee on Uniform Traffic Control Devices (NCUTCD) proposed changes to the MUTCD to include two additional pavement marking symbol options. The first would add “WAIT ON LINES FOR GREEN” text below the standard 9C-7 symbol and present this marking as 9C-7A. The second would portray a slightly modified version of the ‘Option A’ marking from the Columbia, MO, study and present this marking as 9C-7B.

In early 2020, the City of Portland, OR, submitted a request to experiment on the proposed bicycle detector “WAIT HERE FOR GREEN” 9C-7B pavement marking.

In late 2020, FHWA released a draft version of the upcoming MUTCD for comment. While this could change, the draft does further evolve the design from the NCUTCD recommendations.

Based on the referenced studies, cities should consider the use of an enhanced bicycle detector pavement marking. If the standard MUTCD 9C-7 symbol is used, it should be paired with the R10-22 sign, and it is encouraged that the pavement marking symbol have a green backing for increased comprehension.



2020 experimental stencil in Portland, OR

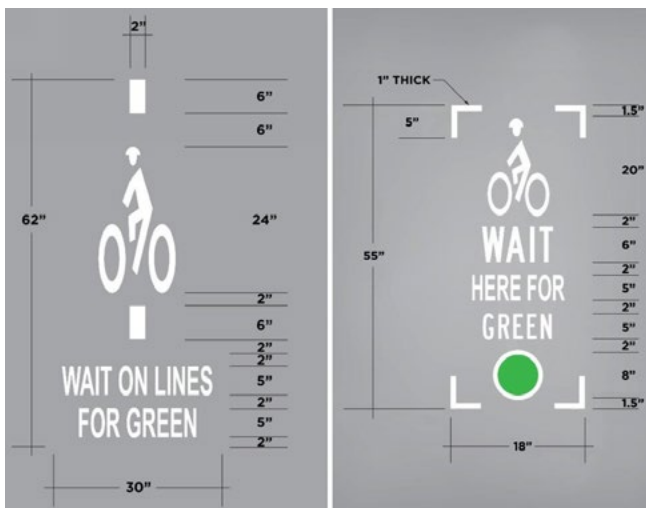

NCUTCD’s 2018 proposed bicycle detector pavement marking additions to the MUTCD: marking 9C-7A (left) and marking 9C-7B (right)

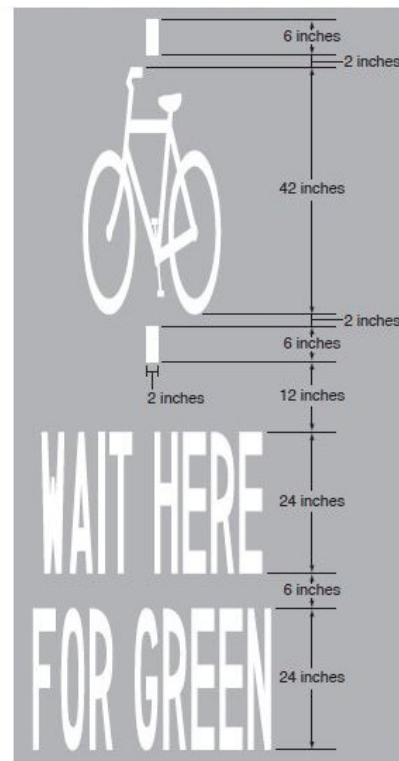

Late 2020 Public Comment Draft MUTCD detector marking (subject to change in final MUTCD)

Bicycle Detection Confirmation Indication

Even if adequate bicycle detection is provided, it is often unclear to a person bicycling if the signal has detected them. Many bicyclists have had numerous experiences of waiting at intersections that have not detected them. If no other vehicles are present, it can often leave the bicyclists with no choice but to cross on red.

In 2012, the City of Portland began to experiment with the use of signal detector confirmation lights. In this application, a blue light was wired to the signal controller to indicate to waiting bicyclists that they have been detected and to increase correct use of the bicycle pavement detector marking. The blue light is programmed to turn on at any point during the signal cycle when a bicyclist is detected and immediately turn off when no bicyclist is detected.

In 2015, the City of Portland released a study on the efficacy of their initial implementation of blue detector lights at SW Moody and SW Sheridan St, which was heavily tied to the detector pavement marking. It found that the light increased use of the stencil from 20 to 50 percent but did not change the amount of red light running. It should be noted that this location was also equipped with a push button. Also in 2015, the City of Portland customized a bicycle signal countdown timer obtained from the Netherlands and added it to an existing bicycle signal at a diagonal intersection crossing. The countdown timer is displayed once a person biking is detected at the stop bar detector and remains displayed until the green phase of the bicycle signal is initiated. The display conveys the relative amount of time remaining until the green phase is initiated by reducing the number of white LEDs shown around the circular display until they are no longer displayed. This additional information displayed to bicyclists is intended to increase compliance at the signal, in addition to confirming the detection of bicyclists at the approach.

In 2018, the Oregon Department of Transportation submitted a final report with the results of the experimentation of a blue light combined with a signal at an intersection in Salem, OR. The “concerns related to the conspicuity of the device in more typical applications led to the decision to investigate the blue confirmation light as well as other similar feedback devices.”



2012 and 2017 installations of blue lights integrated with signals



Blue light integrated with a regulatory sign in Portland, OR

A 2021 study revisited blue light comprehension in Portland and Eugene, OR, through intercept and online surveys of bicyclists using sites with the system installed, as well as video observation of signal compliance. This study confirmed the 2015 study and found that red light compliance did not statistically change. This study also found no statistically significant change in behavior for bicyclists waiting directly over the stencil, though in several cases the percentage of bicyclists using the stencil did decrease.

City of Portland engineers also noted a preference for the blue lights, as it offered a easy way to confirm detector outages and can help in placing the pavement stencil in the most advantageous spot. The research did confirm the usefulness of the supplemental sign.

Overall, this 2021 research found that the blue confirmation light does have an impact to the overall bicycling experience. Fully 80 percent of intercepted bicyclists agreed that the blue light made them feel better about waiting at an intersection and 84 percent agreed that the information is useful to them.

This study also tested the first nearside bicycle signal with an integrated detection/countdown display in the US. Comprehension of the study was very high, with 97 percent of respondents having the correct or partially correct understanding of the device. 86 percent of respondents indicated that they felt better about waiting at an intersection with a countdown timer. Nearside displays are still new for American contexts, with the vast majority of information being delivered far side. Comprehension may increase if the technology becomes more widely used.

Signs combined with confirmation lights have become commercially available in recent years. The example at right utilizes a guide sign format to display a blue detector confirmation light in a similar format to that of a bicycle signal face.

As of 2019, the City of Portland had 19 intersections equipped with blue feedback lights. As of 2020, other cities using a confirmation light include Austin, TX, Santa Clarita, CA, Santa Monica, CA, Seattle, WA, Denver, CO, Salem, OR, Eugene, OR and Corvallis, OR among others.



2015 Bicycle signal countdown timer (left) accompanies bicycle signal and activates upon detection of bicyclists. WACHT message modified to display WAIT. Nearside countdown timer (right) installed in 2020.



Example of a commercially-available blue light integrated with a guide sign

Bicycle Facility Regulatory Blank-out Signs and Warning Beacons

Detection of bicyclists can also allow for the use of regulatory blank-out signs or beacons at unique locations along bike facilities to highlight known conflict zones and more visibly communicate driver expectations and responsibilities.

A common application of blank-out signs used in conjunction with bike facilities is the R10-11 series of signs (No Turn On Red) and/or R3-1 sign combined with a bicycle-specific signal phase. Although static signs can be used in such circumstances, the use of blank-out signs typically result from an agency's desire to allow turns on red during other phases of the signal cycle. A blank-out sign used in conjunction with an actuated bike signal would rely on detection to put a call in to actuate the sign as well.

In 2011, the City of Portland customized a blank-out sign to portray a modified R10-15 sign depicting the need for turning vehicles to yield to bicyclists continuing straight through the intersection. The particular approach is downhill. Therefore, advance detection was utilized to activate the sign and communicate the message well before the potential conflict point. The sign will actuate



Examples of R10-11a and R3-1 blank-out signs

when a bicyclist is detected at the advance detector while approaching the intersection during a green light. Logic was applied to the detection such that the sign would not immediately actuate if a bicyclist approached the intersection during a red light, but would instead delay actuation until the green phase for cross-street traffic terminated. Once actuated, the sign remains actuated through the remainder of the phase. The yield symbol and rectangle bounding 'TURNING VEHICLE' are active elements



Above: LED sign sequence. Below: Left to Right: 1) Bicyclist rolls onto advance detector during green phase. 2) Blank-out sign (upper right of image) actuates. 3) Close-up of right-turning driver yielding to bicyclist while blank-out sign is displayed.

of the sign, flashing on/off while the sign is displayed. Similarly, the bike lane directional arrow advances upward in a staggered manner and continues to repeat the display until the sign is no longer displayed.

Warning beacons positioned in advance of pinch points along high-speed roadways are another application to combine with detection to improve the effectiveness of the warning message. For example, bicyclists traveling through tunnels that have narrow or no shoulders benefit from warning beacons alerting drivers to the likely presence of bicyclists ahead. Rather than relying on a warning beacon that flashes continuously, one that is linked to detection can more accurately inform drivers of the actual traffic conditions to be aware of. If it is determined that bicyclists can safely approach the pinch point at speed, passive detection is encouraged to increase reliability of the warning beacons and reduce inconvenience to bicyclists. A push button detector can be considered at approaches where there is a desire for bicyclists to come to a complete stop and identify a safe gap in traffic before proceeding into the constrained segment of road; however, not all bicyclists will actuate the warning beacons and would therefore be less reliable to drivers as compared to using passive detection.

Physical Amenities To Encourage Detection

Separated bike lanes and their associated buffer space afford the opportunity to install physical amenities associated with the bikeway to encourage waiting in the correct location at a traffic signal in order to be detected. Once such example is a lean rail, primarily meant to allow bicyclists to wait without putting their foot down on the pavement, but can also be used to position waiting bicyclists in the preferred location to be detected. Curbing or medians can also be effective in corralling queued bicyclists into the correct position to be detected.



This button actuated warning beacon alerts motorists to the presence of bicyclists in this tunnel near Lake Tahoe, CA



Bicycle lean rails installed within separated bike lanes in Charlotte, NC (top) and Seattle, WA (bottom)



05 CONCLUSION

This white paper provides substantial detail on a variety of bicycle detection families. The preceding sections were written to be vendor-neutral and not intended to discuss individual products or to promote one vendor over another. Rather, it discusses design considerations that are in most part common to a variety of products within a detection family. In fact, vendors offer dramatically different offerings that provide distinct capabilities even within the same family of detection.

Several cities have extensively experimented with various forms of detection and have found many of the technologies to be inconsistent or temperamental in both their ability to detect presence and count, with counts typically being less accurate than presence. Several of these studies (in particular, in Portland, OR, and Denver, CO) are now at least six years old. The findings of these studies may no longer be accurate due to advances in technology and greater awareness of how to correctly configure it.

In general, accuracy can vary dramatically in each of the remote sensing families through the following:

- Maturity of the technology itself, though updates and improvements being implemented continuously
- Proper adjustment and orientation of the detection and controller software
- Bicyclist behavior (i.e., not stopping within defined detection areas)
- Climate – sun position, ambient temperature, shadows, obstructions, or other factors can impact video and thermal systems
- Systems which rely on battery power or wireless communication

City experience has generally concluded that inductive loops are the most reliable. They are climate-independent and can be adjusted to detect nearly any bicycle. The City of Austin increases loop sensitivity so that there is a low probability of not detecting a bike and tolerates false positives as a preferred condition over non-detections. Loops are, however, inflexible and cannot be easily moved or modified as streets evolve.

Video and infrared-based systems are also generally highly regarded. Camera placement and detection zone settings are critical to maximizing accuracy. In some cases, additional camera(s) dedicated to the bicycle approach will yield better results than ones serving multiple user types. These systems are also flexible and can be quickly reconfigured if needed based on street configuration changes.

Microwave systems can have high accuracy and utility in certain applications, though this technology is not nearly as flexible in as many uses as other families of detection.

In-ground radar offers some flexibility that loops do not, but required significant effort to configure properly in several projects. The need to exhume the sensors for battery replacement in eight to ten years is also a deterrent to many cities.

App-based detection and other emerging technologies may hold promise, but as of 2020 are limited to several pilot studies. Time will tell if they gain acceptance from cities and the public at large.

Alta hopes that this white paper can serve as an educational tool for agencies and consultants in the intersection design process and help them select a suitable bicycle detection device for any given scenario. Most agencies that have been actively working on bicycle detection have, over time, determined what technology works best in their context and have standardized around it.



06 REFERENCES

1. FHWA. Traffic Detector Handbook, 3rd Edition, Volume 1, Chapter 4. Federal Highway Administration, Washington D.C., 2006.
2. FHWA. Manual of Uniform Traffic Control Devices. Federal Highway Administration, Washington D.C., 2009.
3. AASHTO. Guide for the Development of Bicycle Facilities, 4th Edition. American Association of State Highway and Transportation Officials, Washington D.C., 2012.
4. NACTO. Urban Bikeway Design Guide, 2nd Edition. National Association of Transportation Officials, New York, NY, 2012.
5. Patrick Marbas. Traffic Signal Bicycle Detection Study. City of Portland, Portland, OR, 1993.
6. Shanteau. Detecting Bicycles and Motor Vehicles Using the Same Loop Detector, 1st Edition. California, 2007.
7. Gibson. Making Signal Systems Work for Cyclists. Federal Highway Administration, FHWA-HRT-08-004, 2008.
8. Shanteau. Bicycle Detection at Traffic Actuated Signals, Presented to the AB 1581 Subcommittee of the California Traffic Control Devices Committee. California, 2008.
9. Paul Wojciechowski. Columbia, MO Bicycle Pavement Marking Detection Symbol RTE Findings. Alta Planning + Design, Inc., 2017.
10. Boudart, Jesse & Liu, Ryan & Koonce, Peter & Okimoto, Lisa. Assessment of Bicyclist Behavior at Traffic Signals with a Detector Confirmation Feedback Device. Transportation Research Record: Journal of the Transportation Research Board. 2520. 61-66. 10.3141/2520-08, 2015.
11. Boudart, Foster, Koonce, Maus, Okimoto. Improving Bicycle Detection Pavement Marking Symbols to Increase Comprehension at Traffic Signals. ITE Journal, 2017.
12. Monssere, Kothuri, Hurwitz, Cobb, Jashami. Assessment of Bicycle Detection Confirmation and Countdown Devices. Oregon Department of Transportation SPR 825, 2021.

INTERESTED IN LEARNING MORE?

The range of bicycle detection technologies and design strategies detailed in this white paper can be a part of a transformative and inclusive approach to signal design. Alta Planning + Design offers comprehensive traffic analysis and signal design services that can help create locally relevant signal or beacon designs that are optimized to improve the efficiency, safety and comfort for all users. We have successfully implemented many innovative intersections throughout the US and Canada and can help you determine which elements are the most appropriate for the context, work with locally applicable design standards and coordinate installation.



Colorado State University Football fans travel to a game through this Alta designed bicycle signal (Credit: City of Fort Collins)

Contact Us

Joe Gilpin | joegilpin@altago.com

Tobin Bonnell, PE, PTOE | tobinbonnell@altago.com

Matt Fralick, PE, PTOE | mattfralick@altago.com

Kirk Paulsen, PE | kirkpaulsen@altago.com

Lindsay Zefting, PE | lindsayzefting@altago.com