

CITY LIMITS

Setting Safe Speed Limits on Urban Streets



Acknowledgements

NACTO MEMBER WORKING GROUP

Christopher Cairns, City Transportation Engineer, City of Orlando

Najah Casimir, Communications Manager, City of Cambridge Traffic, Parking & Transportation

Charlotte Castle, Deputy Chief of Staff, Managing Directors Office, Philadelphia oTIS

Dongho Chang, City Traffic Engineer, Seattle Department of Transportation

Ethan Fawley, Vision Zero Program Coordinator, City of Minneapolis Public Works

Tim Frémaux, Senior Transportation Engineer, Valley and Western District Operations, Los Angeles Department of Transportation

Lacey Hirtle, Senior Traffic Safety Engineer, City of Vancouver

Matt Kelly, Vision Zero Specialist, Portland Bureau of Transportation

Julia Kite-Laidlaw, Director of Strategic Initiatives, New York City Department of Transportation

James Le, Senior Civil Engineer, Seattle Department of Transportation

Brooke McKenna, Assistant Director for Street Management, City of Cambridge Traffic, Parking & Transportation

Richard Montanez, P.E., Deputy Commissioner for Transportation, Philadelphia oTIS

Ryan Noles, Senior Transportation Planner, City of Boulder

Ryan Reeves, Vision Zero Program Lead, Sustainable Streets Division, San Francisco Municipal Transportation Agency

Lily Reynolds, Deputy Director of Complete Streets, Philadelphia oTIS

Gustave Scheerbaum, P.E., Director of Strategic Initiatives, Transportation, Philadelphia oTIS

Brad Topol, Interim Vision Zero Coordinator, Seattle Department of Transportation

Liliana Quintero, Senior Transportation Engineer, City of Vancouver

Kelley Yemen, Director of Complete Streets, Philadelphia Office of Transportation, Infrastructure, and Sustainability

EXTERNAL REVIEWERS

Sarah Abel, Technical Programs Manager, Institute of Transportation Engineers

Jessica Cicchino, Vice President, Research, IIHS

Charlotte Claybrooke, Active Transportation Program Manager, Washington State Department of Transportation

Jackie DeWolfe, Director of Sustainable Mobility, Massachusetts Department of Transportation

Wen Hu, Senior Research Transportation Engineer, IIHS

Beth Osborne, Director, Transportation for America

Leah Shahum, Executive Director, Vision Zero Network

Eric Sundquist, Director, State Smart Transportation Initiative, University of Wisconsin

Veronica Vanterpool, Principal, V Squared Strategies

ABOUT NACTO

NACTO's mission is to build cities as places for people, with safe, sustainable, accessible, and equitable transportation choices that support a strong economy and vibrant quality of life. We do this by:

- Communicating a bold vision for 21st century urban mobility and building strong leadership capacity among city transportation officials.
- Empowering a coalition of cities to lead the way on transportation policy at the local, state, and national levels.
- Raising the state of the practice for street design that prioritizes people walking, biking, and taking transit.

NACTO EXECUTIVE BOARD

Janette Sadik-Khan, NACTO Chair
Principal, Bloomberg Associates

Robin Hutcherson, NACTO President
Director, Minneapolis Department
of Public Works

Eulois Cleckley, NACTO Vice President
Executive Director, Denver Department of
Transportation & Infrastructure

Michael Carroll, NACTO Secretary
Deputy Managing Director, Office of
Transportation and Infrastructure Systems,
City of Philadelphia

Robert Spillar, NACTO Treasurer
Director of Transportation, City of Austin

Joseph Barr, NACTO Affiliate Member
Representative; Director, Traffic, Parking, &
Transportation, City of Cambridge

NACTO PROJECT TEAM

Corinne Kisner, Executive Director

Kate Fillin-Yeh, Director of Strategy

Zabe Bent, Director of Design

Jenny O'Connell, Program Manager

Matthew Roe, Technical Lead

Alex Engel, Communications Manager

Sindhu Bharadwaj, Policy Associate

Celine Schmidt, Design Associate

Key Terms & Definitions

Absolute Speed Law: A legal environment in which drivers must never drive faster than the posted speed limit, regardless of what they deem safe for conditions.

Basic Speed Law: A legal environment in which drivers must never drive faster than is safe for present conditions, regardless of the posted speed limit.

Design Speed: The speed on which the geometry or physical elements of the roadway is based.

Operating Speed: The speed at which vehicles are traveling along a roadway.

Posted Speed Limit: The maximum lawful speed as displayed on a regulatory sign.

Statutory Speed Limit: The speed limit established under law, which applies in the absence of a posted speed limit.

Target Speed: The highest speed that designers intend drivers to go on a specific street or road.

Speed Limits Conversions

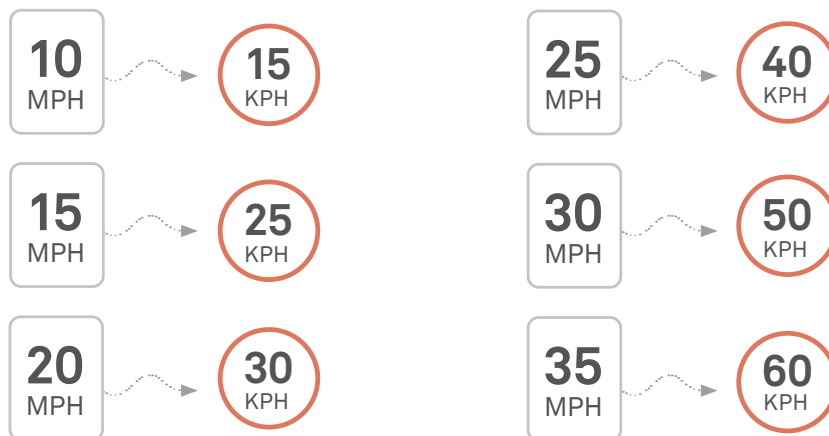

Table of Contents

Acknowledgements	2
Key Terms & Definitions	4
Speed Limits Conversions	4
Executive Summary	6
About This Document	7

1 The Need	8
Rethinking Safety	11
Speed Kills	14
How Speed Kills	15
Designed to Fail: The problem with percentile-based speed limits	18
Speed Limit Changes Have Big Impacts	22

2 The Tools	26
Tools to Change Speed Limits	28
Authority to Change Speed Limits	29
Combining Tools	31
Case Studies in Lowering Speed Limits	35

3 The Right Speed Limits	40
Recommended Speed Limits	42
Default Speed Limits	44
Defining Slow Zones	52
Corridor Speed Limits / Conducting Safe Speed Surveys	56

4 Checklists	90
---------------------------	-----------

Executive Summary

We cannot reduce traffic fatalities on US city streets without reducing speeds.

More than 35,000 people die in traffic crashes on US roads each year, and millions more are seriously and often permanently injured. The United States has the highest fatality rate in the industrialized world; double the rate in Canada and quadruple that in Europe. While traffic fatalities may seem like an intractable issue, city governments have the power to reduce the frequency and severity of traffic crashes by reducing motor vehicle speeds.

Addressing speed is fundamental to making streets safer. Vehicle speed increases both the likelihood of a crash, as well as the severity of the crash, as it diminishes drivers' ability to recognize and avoid potential conflicts. In addition, on streets with higher speeds and higher speed limits, traffic engineers have fewer design options to increase safety.

In cities, transportation agencies have long understood that motor vehicle speed plays a key role in fatal and serious crashes, and have sought to reduce speeds through design and regulation in order to save lives. But speed limit reductions have remained out of bounds for many city transportation agencies because authority over speed limits, even on city streets, is often held at the state level, and is commonly tethered to the practice of using the existing speeds on a street to determine what the speed limit should be. This flawed model uses the current behavior of individuals to determine the speed limit, instead of allowing engineers and planners to set the limit at the speed that will create the best, safest conditions for all road users. The result is higher speeds and speed limits over time.

Practitioners often find themselves with limited recourse to address these challenges because they lack an alternative method for

setting speed limits in urban areas. In many places, cities have turned to increased police enforcement to compensate for restrictive engineering and speed limit setting policies, a practice that is not proven to reduce serious injuries or fatalities, and often increases risk for Black, Indigenous, and people of color (BIPOC) on city streets.

This document, *City Limits*, is intended to provide city practitioners with guidance on how to strategically set speed limits on urban streets, using a Safe Systems approach, to reduce traffic fatalities and injuries. Recognizing that city authority to set speed limits varies by jurisdiction, *City Limits* offers three tools for setting speed limits on urban streets:

Setting **Default Speed Limits** on many streets at once.

Designating **Slow Zones** in sensitive areas.

Setting **Corridor Speed Limits** on high priority major streets using a Safe Speed Study.

City Limits maps a new path for US cities, codifying speed limit setting best practices that have been tested and documented in cities across North America. Cities can create better and safer outcomes for all by adopting these speed limit setting practices as part of their traffic fatality reduction or Vision Zero programs. By managing speeds, cities can save lives.

About This Document

In 2018, NACTO convened a working group of major US cities to develop new robust guidance for setting speed limits on urban streets that could provide an alternative to the highway-focused federal recommendations. Over the course of the following 18 months, transportation staff from 19 cities helped to write and review the guidance and provided technical expertise based on their experience developing speed management strategies and programs and implementing lower speed limits in their own cities.

The resulting guidance, *City Limits*, provides cities with clear technical and policy guidance on setting safe speed limits on city streets. All of NACTO's Member Agencies (81 members at the time of final review) have approved this guidance. The technical guidance and recommended maximum speed limits in this document are based on input from NACTO member agencies, academic studies about speeds that minimize conflict and risk, and best practices in cities across the world.

Unlike existing national guidance, *City Limits* focuses on urban streets, which pose the most challenging scenarios for determining speed limits and are where the majority of pedestrian and cyclist fatalities occur. In this document, urban streets refer to most of the categories of streets found in North American cities, including local, primarily residential streets, mixed use corridors, transit corridors, high density downtown streets, and urban arterials

with commercial, residential, or retail uses along one or both sides. This guidance is also applicable on streets like these in non-urban areas. This guidance is not applicable on limited access streets, even within cities, or on rural or very low density streets with limited multimodal use.

Finally, the speed limit setting guidance contained in *City Limits* is only one piece of a larger, essential discussion around how to make streets truly safe for everyone. Speeding vehicles pose a significant, specific, and deadly threat, but comprehensive safety on city streets and public spaces involves a more holistic consideration of risks—from accessibility to gender identity-based harassment to racial violence. In particular, speed enforcement as currently practiced poses additional, disproportionate health and safety risks especially to Black and Latinx people. Manual police enforcement is a less effective way to manage speeds down over time than street design and engineering changes, and can create dangerous physical and mental health impacts for Black, Indigenous, and people of color (BIPOC), as well as other marginalized road users. This resource touches on speed enforcement, but it is not the focus of this guidance. *City Limits* addresses speed limit setting policy which, paired with street design, is the best tool for reducing the health and safety risks posed by vehicular speeds.



LUCIEN MERRYWEATHER, 9
ALLISON LIAO, 3
KIKO SHAO, 5
RENEE THOMPSON, 16
SAMUEL COHEN ECKSTEIN, 12
LUIS BRAVO, 18
TENZIN DRUDAK, 16
OLVIN YHAR FIGUERO, 3
PURAN THAPA, 7
SARA KISHIK, 15
AMAR DIARRASSOUBA, 6
DENIM McLEAN, 2
ZULEMI TORRES, 16
MARVIN RAMIREZ, 18
ARIEL RUSSO, 4

LUCIEN MERRYWEATHER, 9
ALLISON LIAO, 3
KIKO SHAO, 5
RENEE THOMPSON, 16
SAMUEL COHEN ECKSTEIN, 12
LUIS BRAVO, 18
TENZIN DRUDAK, 16
OLVIN YHAR FIGUERO, 3
PURAN THAPA, 7
SARA KISHIK, 15
AMAR DIARRASSOUBA, 6
DENIM McLEAN, 2
ZULEMI TORRES, 16
MARVIN RAMIREZ, 18
ARIEL RUSSO, 4
KYRILLOS GENDY, 5
JAIED GIGUERO, 2



1

The Need

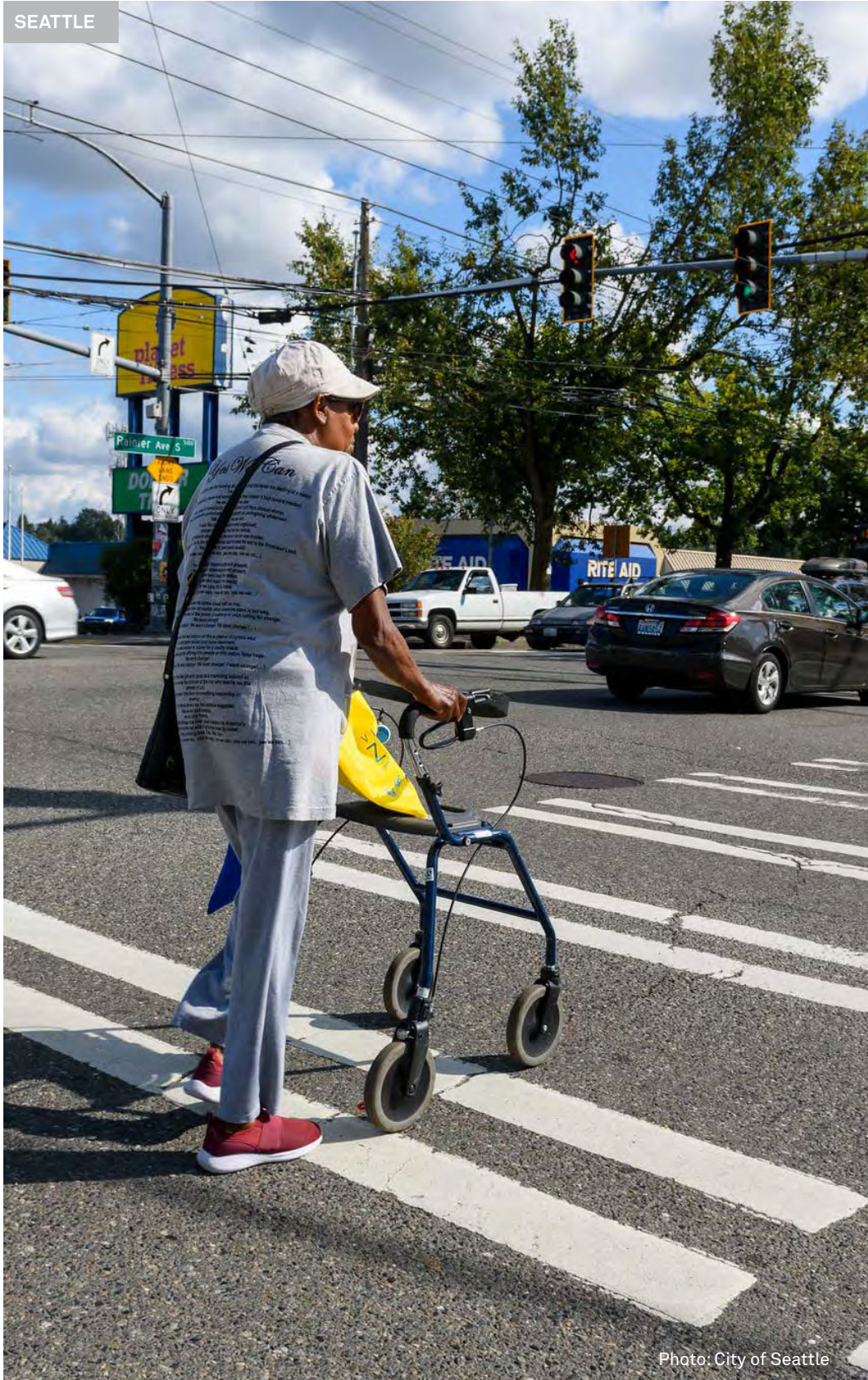

SEATTLE

Photo: City of Seattle

Rethinking Safety

In 2018 alone, drivers killed 36,560 people on US roads and seriously injured millions more.^{1,2} These tragedies are the result of a failed approach to traffic safety that prioritizes speed and convenience over human lives.

Experience from other industrialized countries shows that fewer traffic deaths and safer roads are possible. Rather than focusing on individual behavior, these countries focus on changing the policies and engineering decisions that create unsafe conditions. This technique, also known as a Safe Systems approach, is the guiding philosophy behind the safer streets in European Union and Scandinavian countries, which have, on average, a per capita traffic fatality rate that is half and a third, respectively, of that in the United States.³

Safety for all road users must be set as the foremost goal, and all decisions must be made based on how well they advance work toward zero deaths.

US streets are becoming especially dangerous for people walking and biking. Between 2009 and 2018, pedestrian deaths from traffic crashes in the US grew by 46%, reaching a nearly 3-decade high of 7,354 people killed by vehicles in 2018 alone.^{4,5} This rate means that people walking and biking are an increasingly large percentage of all fatalities on the road. For the past five years, pedestrians and cyclists have accounted for almost 20% of all road fatalities, despite making up only 11% of road users.^{6,7} And this number is on the rise. From 2008 to 2018, cyclist and pedestrian fatalities increased by 38% versus a 12% decline for vehicle occupants.⁸

Compounding these statistics, reliance on increased police enforcement to address dangerous driving in the name of “safety” has contributed to the disproportionate number of Black people stopped, injured, and killed by the police.⁹

PEDESTRIAN FATALITIES HAVE BEEN STEADILY RISING SINCE 2009

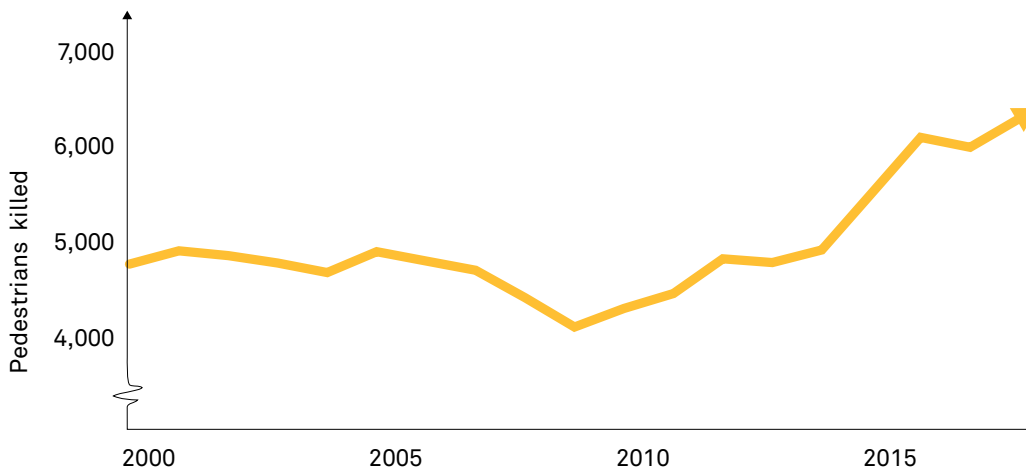

In cities, where the vast majority of pedestrians and cyclists are killed, transportation agencies have long understood that motor vehicle speed plays a key role in fatal and serious crashes, and have sought to reduce speeds and save lives. But speed limit reductions have remained out of bounds for many city transportation agencies because authority over speed limits, even on city streets, is often held at the state level, and is commonly tethered to the practice of using the existing speeds on a street to determine what the speed limit should be. This method results in higher speeds and speed limits over time.¹⁰

If the US approached speed limit setting using a Safe Systems approach, engineers would determine the speed that is safest for all people using the street and then build

infrastructure to support that speed. Instead of being forced upward over time, speeds, and fatalities, would go down as they have in the countries that use such approaches.

To reduce traffic deaths and severe injuries in the US, transportation policymakers must change their approach. Safety for all road users must be set as the foremost goal, and all decisions—about speed, infrastructure, allocation of parking and other curbside uses, enforcement, and maintenance—must be made based on how well they advance work toward zero deaths. By taking a holistic, Safe Systems approach to street design, cities can reduce speeds, build safer streets, and save lives.

TRAFFIC FATALITIES ARE DECLINING IN MOST OTHER INDUSTRIALIZED COUNTRIES, BUT RISING IN THE US¹¹

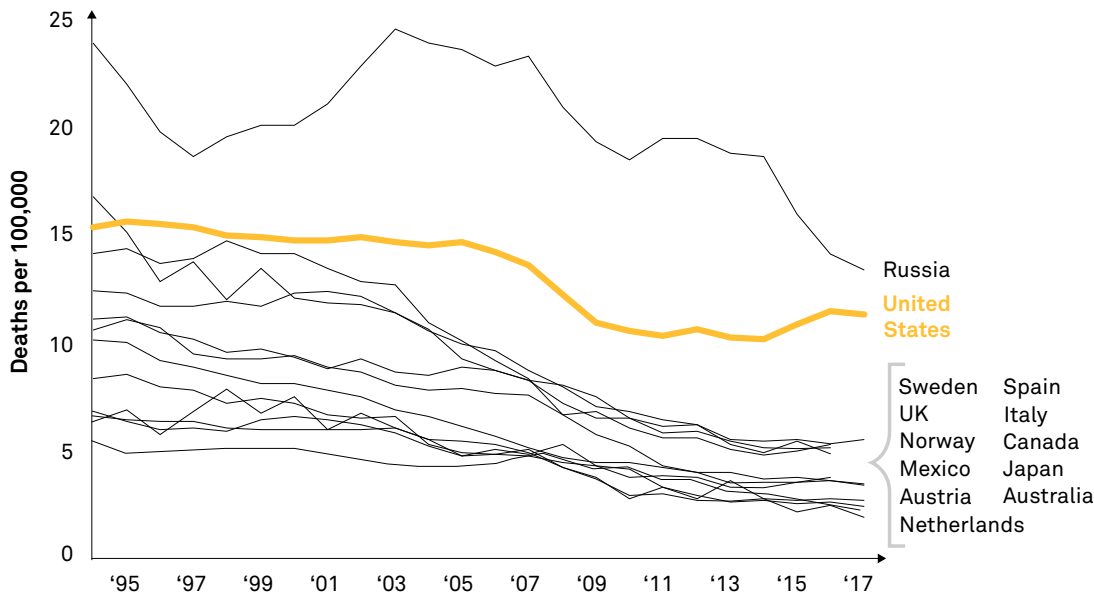



RACISM EXACERBATES THE DANGERS OF SPEEDING

Structural and individual racism exacerbate the dangers posed by speed. In their 2019 *Dangerous by Design* report, Smart Growth America finds that Black, Indigenous, and Latinx people are more likely than White people to be struck and killed by a driver.¹² Street conditions are often worse in low-income neighborhoods and those where people of color are the majority. Historically, in many cities, redlining justified underinvestment in public services for communities of color, while past and current highway siting decisions, suburban-focused traffic engineering practices, and disinvestment in urban cores, result in substandard, dangerous streets in predominantly low-income, immigrant, and BIPOC communities.¹³

Recent studies from Portland State University and the University of Nevada, have found racial bias in how quickly or frequently drivers yield to pedestrians in crosswalks.^{14,15} In particular, in higher-income neighborhoods, researchers found that drivers failed to yield

to a White pedestrian actively crossing in the crosswalk only about 3% of the time versus 21% of the time for a Black pedestrian.¹⁶

Finally, relying on traffic stops as a primary method for managing speeds can hinder larger efforts to improve overall community safety on streets and deepen the role of transportation in structural poverty, where enforcement targets low-income communities. According to the Department of Justice, about half of all interactions with police begin with a traffic stop or crash.¹⁷ But data shows that when enforcing traffic laws, police disproportionately stop Black people and other people of color, sometimes with fatal consequences.¹⁸ By focusing only on reducing traffic fatalities at the cost of increasing risk of fatalities due to police violence and undue stress, transportation planners, engineers, and practitioners erode their credibility with the communities they serve and undercut the momentum for safer streets as a whole.

Speed Kills

Speed is a central factor in traffic deaths. The National Highway Traffic Safety Administration reports that speed was a factor in a quarter of all fatal crashes in 2018.¹⁹ As speed limits and speeds increase, so do fatalities. Researchers from the Insurance Institute for Highway Safety (IIHS) found that a 5 mph increase in the maximum speed limit was associated with an 8% increase in the fatality rate on interstates and freeways, and a 3% increase in fatalities on other roads.²⁰

Vehicle speed at the time of impact is directly correlated to whether a person will live or die. A person hit by a car traveling at 35 miles per hour is five times more likely to die than a person hit by a car traveling at 20 miles per hour.²¹ The risk of death at every speed is higher for older pedestrians and pedestrians hit by trucks and other large vehicles.²²

High speed crashes are more likely to occur than crashes at lower speeds and, when they do occur, they're more likely to be deadly.

Higher speeds are more likely to result in crashes because the amount of time a driver has to hit the brakes or swerve decreases at higher speeds, while vehicle braking distances increase.^{23,24} A driver going 40 mph travels twice as far as a driver traveling at 25 mph before coming to a complete stop.^{25,26,27} Research also shows that drivers have less peripheral awareness at higher speeds and are less likely to see or predict potential conflicts such as people crossing the street or children playing.²⁸ Meanwhile, crashes are more likely to be fatal at higher speeds because these crashes are more forceful.

As a result, evidence shows that small reductions in speed result in large safety gains.²⁹ The *Highway Safety Manual* reports that a 1 mph reduction in operating speeds can result in a 17% decrease in fatal crashes.³⁰ A separate study found that a 10% reduction in the average speed resulted in 19% fewer injury crashes, 27% fewer severe crashes, and 34% fewer fatal crashes.³¹

THE LIKELIHOOD OF FATALITY INCREASES EXPONENTIALLY WITH VEHICLE SPEED³²

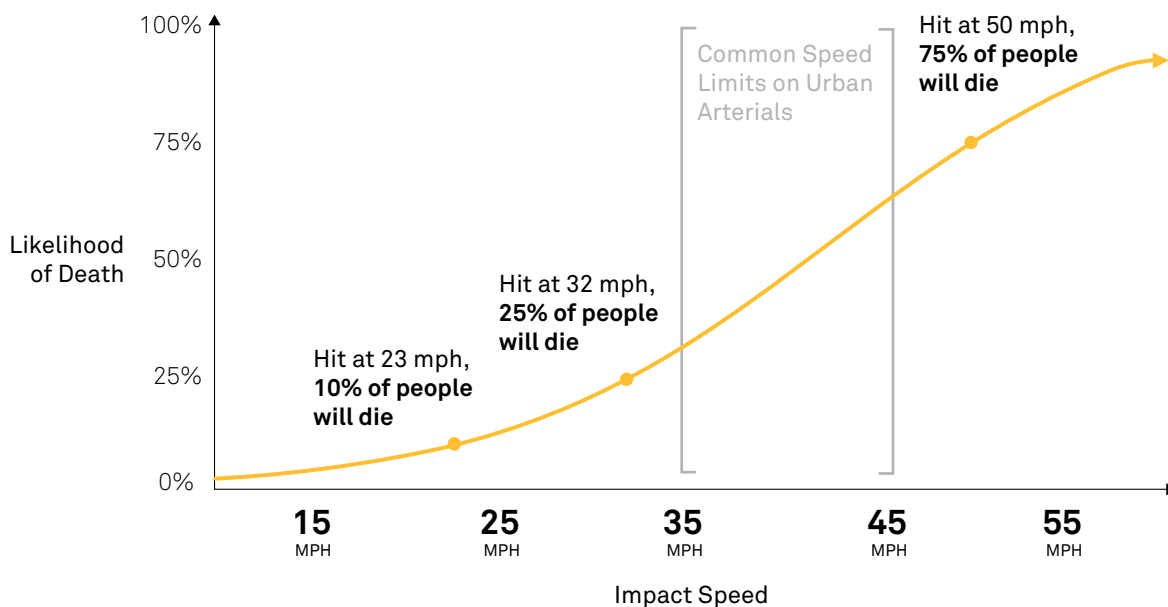

How Speed Kills

1

Crashes at higher speeds are more **forceful** and thus more likely to be fatal

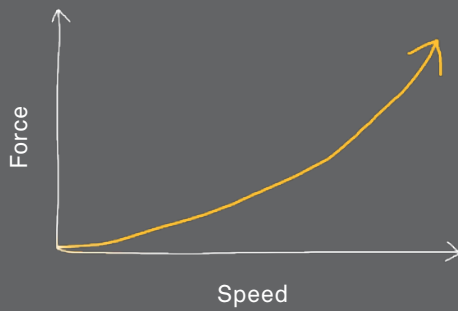

2

Drivers traveling at higher speeds have a **narrower field of vision**

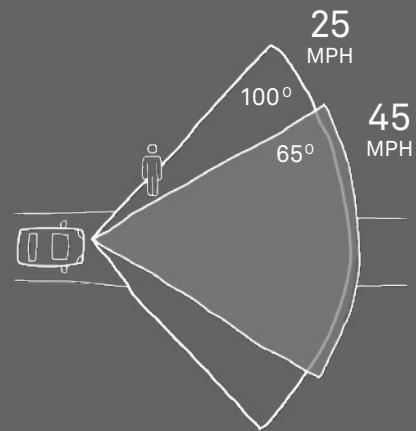

3

Drivers traveling at higher speeds **travel further** before they can react



4

Vehicles traveling at higher speeds have **longer braking distances**

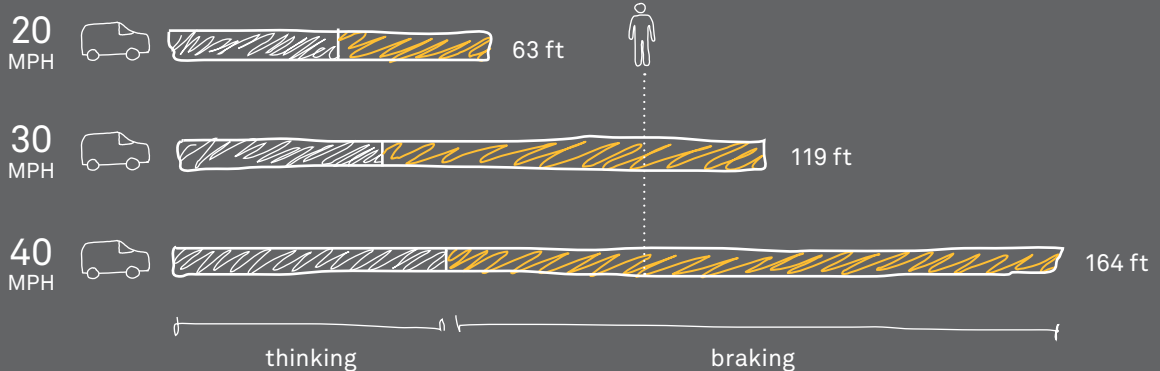

High speed driving is particularly deadly where different types of road users share space and must interact frequently. In the US, fatal crashes are disproportionately clustered on a small group of high speed, auto-oriented streets, known as urban arterials. Between 2014 and 2018, urban arterials accounted for 29% of all fatal crashes in the US and half (49%) of all fatal crashes involving people biking or walking, despite making up only 6% of US roadways.³³

Urban arterials are typically signed for 35-45 miles per hour or higher, and are designed to support high speeds by featuring wide, highway-width lanes, sweeping turn radii, and few places to stop for people to cross. In many cities, urban arterials often lack basic protections for people outside of cars, such as sidewalks, even when bus stops are present or when the adjacent retail/commercial land uses encourage people to go there.

INCREASING VEHICLE SIZE COMPOUNDS THE DANGERS OF SPEED

In the US, the trend toward larger vehicles compounds the problems posed by excessive speeds. In 2017, 43% of pedestrian and cyclist fatalities involved an SUV, pickup truck or other light truck.³⁴ In 2015, the National Highway Traffic Safety Administration found that pedestrians are two to three times more likely to die when hit by an SUV or pickup than by a passenger car.³⁵

Larger vehicles are more lethal than smaller ones for two main reasons: they are heavier, which increases the force of the impact when combined with speed;

and they have a taller frame, which increases the likelihood that, if struck, a person (especially a child) will be pulled under the vehicle rather than pushed onto the hood.

The US trend toward larger, more dangerous vehicles is only growing. SUVs and pickup trucks outsold sedans more than three-to-one in 2019, and companies like Ford and Fiat Chrysler have announced that they will stop producing the vast majority of their sedans and compact cars.³⁶





TWO TAKES ON SAFETY-FIRST SYSTEMS APPROACHES

Vision Zero saves lives

Shifting an entire system from unsafe to safe is not just an aspiration. Many US cities have adopted safety-first programs, to varying degrees of success. Vision Zero, Injury Minimization, and Safe Systems programs affirm safety as the top transportation priority and the most effective way to eliminate traffic fatalities. Establishing a safety-first program:

- › Signals a commitment to zero traffic deaths on city streets
- › Asserts a belief that such a goal is attainable
- › Accepts the role of officials, engineers, and planners in making streets safer

Safety-first programs recognize that although human error is inevitable, fatalities and severe injuries are preventable through street design and management choices. Successful safety programs systematically change the way streets operate to keep users safe, even when individuals make mistakes.

Sweden has created one of the most successful Vision Zero programs to date. In 1997, when Sweden adopted its Vision Zero program, there were more than 7 traffic deaths per 100,000 people. Today, despite more than 20 years of growth in traffic volume, this number has dropped to 3 people per 100,000.³⁷

US Aviation makes an impact

By nearly every measure, commercial aviation is the safest transportation mode in the United States. There were 3 fatal crashes between 2010 and 2017, compared to 17 fatal crashes in 1960 alone.³⁸ These safety gains are the result of systemwide, interdisciplinary approaches to managing risk on the part of regulators and the commercial aviation industry.

In 1997, the White House Commission on Aviation Safety & Security and the National Civil Aviation Review Commission released reports calling for the Federal Aviation Administration (FAA) and airlines to work together to reduce fatal accidents.³⁹ In response, the FAA partnered with airlines to form the Commercial Aviation Safety Team (CAST), which uses incident data to discern safety priorities, deploys interdisciplinary teams to determine underlying crash causes, and applies interventions based on their findings.

In 2009, Continental Flight 3407 crashed, killing all 49 people on board and one person on the ground. Pilot error and fatigue were the listed causes. By 2013, the FAA dramatically increased both training and rest requirements for pilots.⁴⁰ Humans in the commercial aviation industry make mistakes. However, a systems approach to safety has resulted in substantive safety gains across the entire industry.

Designed to Fail

THE PROBLEM WITH PERCENTILE-BASED SPEED LIMITS

Current speed limit setting practice in the US uses a percentile-based method, typically set at the 85th percentile, to determine speeds. Traffic engineers record how fast vehicles are traveling on a road, determine the speed that 85 percent of drivers are traveling at or below, then set the new speed limit by rounding from that speed to the nearest 5 mph increment. Traffic engineers who use the 85th percentile method are instructed to raise the speed limit when more than 15% of drivers are driving faster than posted signs. This method forces engineers to adjust speed limits to match observed driver behavior instead of bringing driver behavior in line with safety goals and the law. When it comes to safety, this method is designed to fail.

Percentile-based speed limit setting methods fail at keeping people safe because they set a permanently moving target based on current human behavior, not safety.

Two issues are at play. First, percentile-based models are designed to respond to extremes. When enough people drive faster than the set percentile, the model rewards them by instructing traffic engineers to increase the posted speed.

Second, people decide how fast to drive based on both the street's design and cues such as the posted speed and other drivers' speeds. Researchers originally recommended using the 85th percentile approach to determine posted speeds, assuming that drivers always travel at reasonable speeds.⁴¹ But a growing body of research shows that drivers base their decisions at least partially on the posted speed limit.^{42,43} When they see higher posted limits, and see the resulting increased speed of their peers, they drive faster too, which results in an increased speed of the street overall.⁴⁴

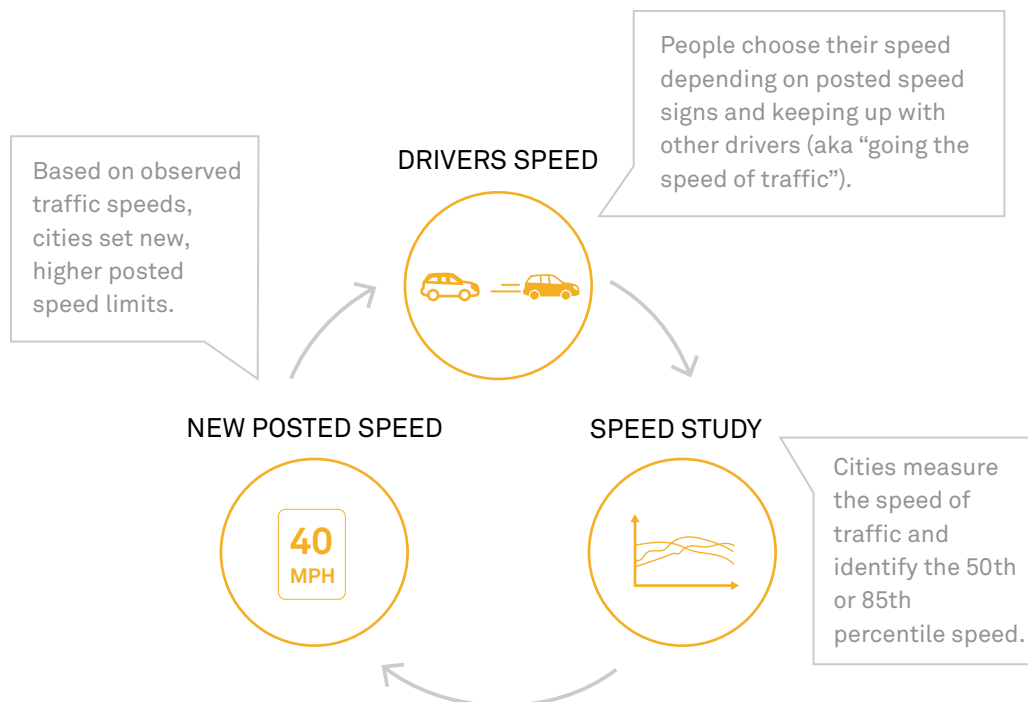

Posting higher speed limits does not increase compliance with the law. Even when higher speed limit signs are posted, some number of people will still choose to drive 5-15 mph faster than the posted limit. These “high-end” speeders travel even faster as speed limits rise and typically spread out over a

wider range of speeds. This can increase the likelihood of crashes because people are traveling at increasingly different speeds, and increases the likelihood that crashes will be fatal because they occur at higher speeds.

USING PERCENTILES TO DETERMINE SPEED LIMITS RESULTS IN INCREASED SPEEDS OVER TIME

○ = 5 vehicles (out of 100) recorded in speed study

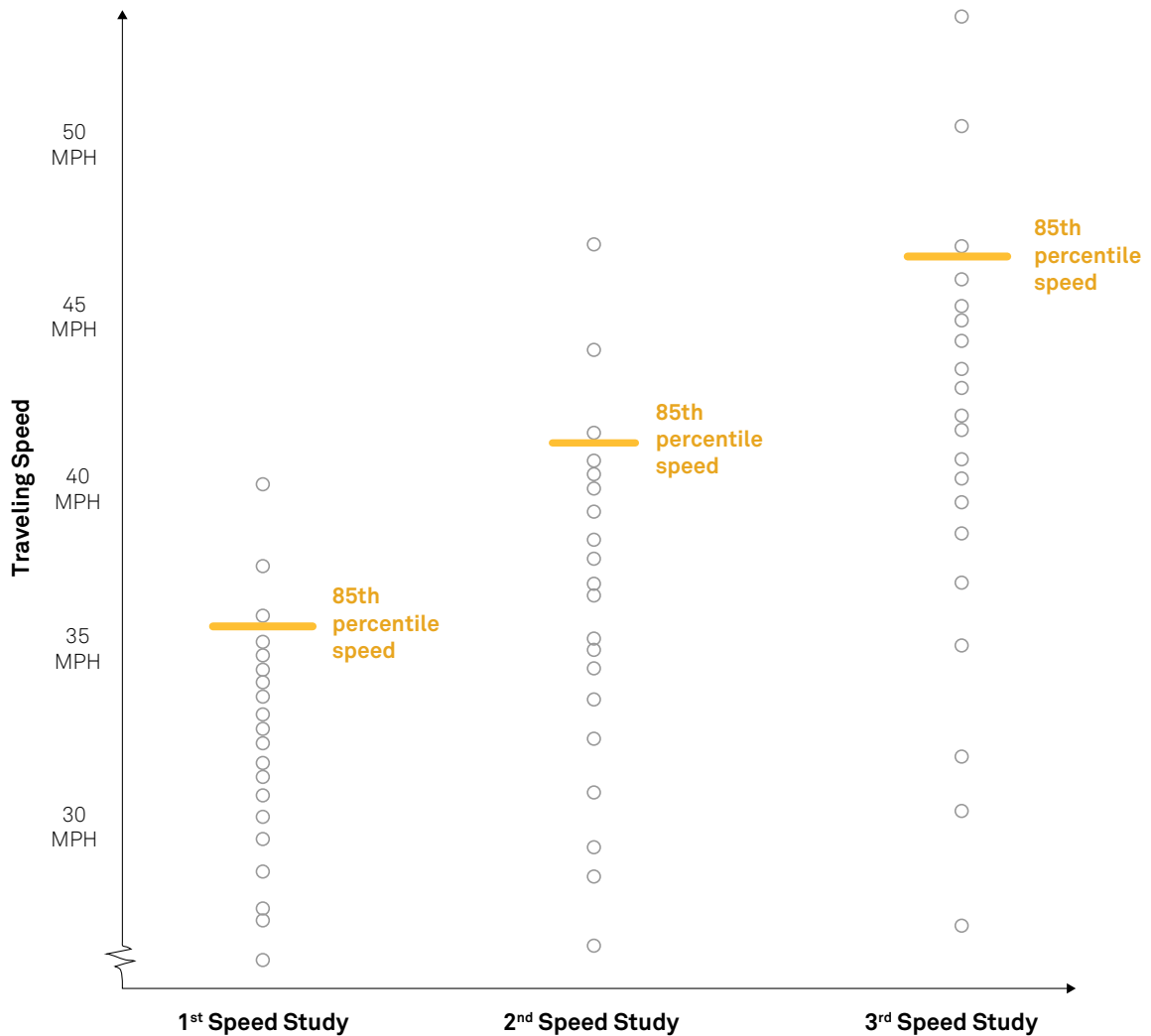

In cities and other urban contexts, percentile-based speed limit setting methods are particularly dangerous because they are based on outdated research that is inapplicable in urban settings.⁴⁵ The 1940s-era research supporting the 85th percentile relied on self-reported crash data and was conducted on two-lane rural highways, devoid of multimodal activity.⁴⁶ But these historic roads are a far cry from the vibrant streets and arterials that typify city streets today. In particular, rural roads and highways lack the type or volume of conflicts found in cities, such as people crossing the street, and people biking, walking, or rolling at a variety of speeds. They also lack driveways, loading, parking, and double-parking.

Los Angeles' experience with Zelzah Avenue provides a telling example of the dangers of percentile-based speed limit setting. In 2009, Los Angeles conducted a traffic speed study and raised the speed limit on Zelzah Avenue from 35 mph to 40 mph.⁴⁷ In 2018, the city again studied existing traffic speeds, and again raised the speed limit, this

time to 45 mph. While other additional factors may also have played a role in speeds inching up over time, absent any design or land use changes, the increase suggests that the 85th percentile operating speed can shift over time in accordance with the posted speed limit. Notably, this time period in LA corresponded to a 92 percent increase in pedestrian fatalities.⁴⁸

The most commonly cited alternative for the 85th percentile is USLIMITS2, an online tool developed by the Federal Highway Administration that incorporates other factors when determining speed limits. USLIMITS2 is a step forward in that it allows practitioners to also consider the street's most exposed users. However, it still relies on the 85th or, more commonly in urban areas, the 50th percentile operating speed, which is often still much higher than is safe. Relying on a percentile-based system focused on current driver behavior, rather than a defined safety target to set speed limits, significantly limits cities' ability to reduce traffic deaths.

Relying on a percentile-based system focused on current driver behavior, rather than a defined safety target to set speed limits, significantly limits cities' ability to reduce traffic deaths.

RURAL CONNECTICUT



Photo: State of Connecticut DOT

The research supporting the use of the 85th percentile method was conducted on rural, two-lane highways.

AUSTIN



Photo: Capital Metro

But streets in cities are full of people walking, biking, using transit, and driving all in close proximity. The 85th percentile method for setting speed limits has never accounted for these types of conditions.

Speed Limit Changes Have Big Impacts

Rethinking how urban speed limits are set improves safety for people in a number of ways. Even changing the posted speed limit sign creates safety benefits and allows cities to provide more and better safety treatments, and improve overall quality of life.

A growing body of research shows that speed limit changes alone can lead to measurable declines in speeds and crashes, even absent enforcement or engineering changes. For example, a 2017 Insurance Institute for Highway Safety study in Boston found that just reducing the citywide speed limit to 25 mph from 30 mph reduced speeding overall and dramatically decreased the instances of high-end speeding (vehicles traveling faster than 35 mph).⁴⁹

Similarly, in Canada, researchers at The Hospital for Sick Children found measurable safety gains after Toronto lowered speed limits from 40 kilometers per hour (~25 mph) to 30 kilometers per hour (~20 mph) on a number of local streets.⁵⁰

Recent efforts in Seattle underscore this pattern. There, the Department of Transportation saw significant speed and crash reductions when they lowered the speed limit to 25 mph and increased the density of speed limit signs on select streets.

Reducing the posted speed limit unlocks a variety of engineering and design tools that can further increase safety on a street and support other policy goals. Typically, the posted speed of a street dictates what infrastructure and safety elements can be included in the final street design. For example, if the posted speed is 30 mph, a wider curb radius will be required than if the posted speed is 25 mph. The wider curb radius increases exposure and risk for people walking and biking.⁵¹ All too often, essential pieces of safety infrastructure—raised crossings, bike lanes, corner bulb-outs—are ironically ineligible for inclusion in a street redesign because drivers are currently going too fast. In effect, the street is too dangerous to build safety infrastructure.

Reducing posted speeds creates opportunities for safer street designs that also support other policy goals. Similar to curb radii decisions, often infrastructure that supports transit and other sustainable modes like biking and walking, cannot be included in a design if the posted speed is too high. City policies around safety, economic sustainability, equity, carbon emissions reductions, and increased transit, bike, and walk mode share are interconnected. Rethinking speed limits unlocks the door for better design and safer streets, which increases opportunities for all.

All too often, essential pieces of safety infrastructure—raised crossings, bike lanes, corner bulb-outs—are ironically ineligible for inclusion in a street redesign because drivers are currently going too fast.

SPEED LIMIT REDUCTIONS ALONE CAN REDUCE SPEEDS AND CRASHES

CASE STUDY

TORONTO

In Toronto, Researchers at The Hospital for Sick Children found that on streets where speed limits were lowered from 40 kph to 30 kph, there was a 28% decrease in the number of collisions between pedestrians and motor vehicles and a 67% decline in the number of fatal and serious injuries on streets with speed limit reductions.

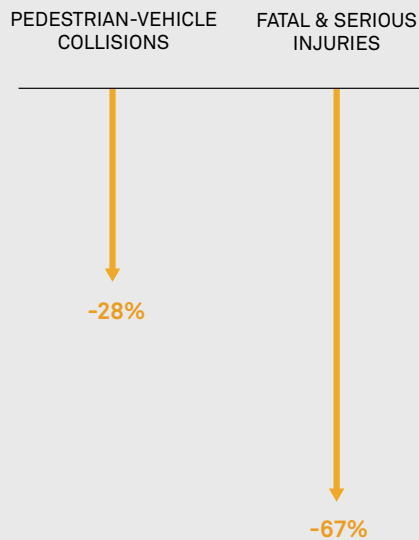

CASE STUDY

SEATTLE

Seattle DOT replaced existing 30 mph signs spaced 1 mile apart with 25 mph signs placed ¼ mile apart on a 1.3 mile stretch of Greenwood Ave. North / Phinney Ave. North, and saw reductions in 85th and 50th percentile speeds, as well as all crashes and injury crashes. During this time, the city did not increase marketing or enforcement, nor did they make any engineering changes.

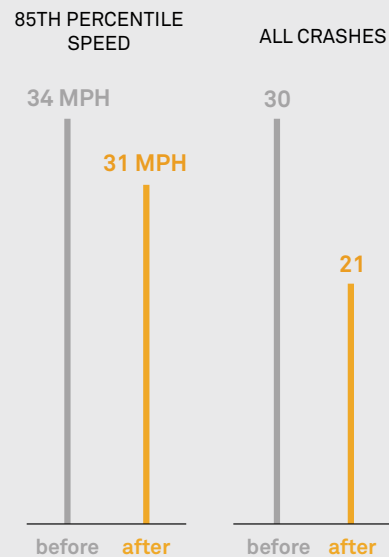

Section 1 Endnotes

1. National Highway Traffic Safety Administration. Fatality Analysis and Reporting System. Retrieved from: <https://www.nhtsa.gov/es/research-data/fatality-analysis-reporting-system-fars>.
2. National Highway Traffic Safety Administration. Table 54: Persons Killed or Injured, by Person Type and Injury Severity, 2017. Retrieved from: <https://cdan.nhtsa.gov/SASStoredProcess/guest>.
3. World Health Organization. Global Health Observatory data repository: Road traffic deaths. Retrieved from <http://apps.who.int/gho/data/node.main.A997>.
4. National Highway Traffic Safety Administration (October 2019). 2018 Fatal Motor Vehicle Crashes: Overview. Retrieved from: <https://crashstats.nhtsa.dot.gov/Api/Public/ViewPublication/812826>.
5. National Highway Traffic Safety Administration. Fatality Analysis and Reporting System. Retrieved from: <https://www.nhtsa.gov/es/research-data/fatalityanalysis-reporting-system-fars>.
6. Ibid.
7. National Household Travel Survey (2017). Number of Person Trips by Mode. Retrieved from: <https://nhts.ornl.gov/person-trips>.
8. National Highway Traffic Safety Administration. Fatality Analysis and Reporting System. Retrieved from: <https://www.nhtsa.gov/es/research-data/fatalityanalysis-reporting-system-fars>.
9. Stanford Open Policing Project. Retrieved from: <https://openpolicing.stanford.edu/>.
10. National Traffic Safety Board (25 July, 2017). Reducing Speeding-Related Crashes Involving Passenger Vehicles. Retrieved from: <https://www.ntsb.gov/safety/safety-studies/Documents/SS1701.pdf>.
11. Organisation for Economic Co-operation and Development. Road accidents. Retrieved from <https://data.oecd.org/transport/road-accidents.htm>.
12. Smart Growth America (2019). Dangerous by Design. Retrieved from: <https://smartgrowthamerica.org/app/uploads/2019/01/Dangerous-by-Design-2019-FINAL.pdf>.
13. Cusick, Daniel (21 Jan, 2020). "Past Racist 'Redlining' Practices Increased Climate Burden on Minority Neighborhoods". E&E News. Retrieved from: <https://www.scientificamerican.com/article/past-racist-redlining-practices-increased-climate-burden-on-minority-neighborhoods/>.
14. Goddard, Tara et al. (August 2015). Racial bias in driver yielding behavior at crosswalks. Transportation Research Part F: Traffic Psychology and Behaviour, 33, pp 1-6. Retrieved from: <https://www.sciencedirect.com/science/article/abs/pii/S1369847815000923>.
15. Coughenour, Courtney, et al. (January 2017). Examining racial bias as a potential factor in pedestrian crashes. Accident Analysis & Prevention, 98, pp. 96-100. Retrieved from: <https://www.sciencedirect.com/science/article/abs/pii/S000145751630361X?via%3Dihub#abst0010>.
16. Ibid.
17. US Department of Justice (October 2018). Contacts Between Police and the Public, 2015. Retrieved from: <https://www.bjs.gov/content/pub/pdf/cpp15.pdf>.
18. Stanford Open Policing Project. Retrieved from: <https://openpolicing.stanford.edu/findings/>.
19. National Safety Council. Motor Vehicle Safety Issues: Speeding. Retrieved from: <https://injuryfacts.nsc.org/motor-vehicle/motorvehicle-safety-issues/speeding/>.
20. Farmer, Charles (April 2019). The effects of higher speed limits on traffic fatalities in the United States, 1993–2017. Retrieved from: <https://www.iihs.org/api/datastoredocument/bibliography/2188>.
21. Tefft, B.C. (2011). Impact Speed and a Pedestrian's Risk of Severe Injury or Death. AAA Foundation for Traffic Safety. Retrieved from: <https://aaafoundation.org/impact-speed-pedestrians-risk-severe-injury-death/>.
22. Ibid.
23. Transportation Research Board (2012). NCHRP Report 600: Human Factors Guidelines for Road Systems. Retrieved from: http://onlinepubs.trb.org/onlinepubs/nchrp/nchrp_rpt_600second.pdf, pp. 5-12.
24. American Association of State Highway and Transportation Officials (2001). A Policy on Geometric Design of Highways and Streets. Retrieved from: https://www.bestmaterials.com/PDF_Files/geometric_design_highways_and_streets_aashto.pdf, pp. 56.
25. National Highway Traffic Safety Administration (August 2015). Safety Facts. Retrieved from: https://one.nhtsa.gov/nhtsa/Safety1nNum3ers/august2015/S1N_Aug15_Speeding_1.html.
26. University of Pennsylvania School of Engineering (April 2015). Vehicle Stopping Distance and Time. Retrieved from: https://nacto.org/wp-content/uploads/2015/04/vehicle_stopping_distance_and_time_upenn.pdf.
27. Layton, Robert, and Karen Dixon (April 2012). Stopping sight distance. Retrieved from: <https://cce.oregonstate.edu/sites/cce.oregonstate.edu/files/12-2-stopping-sight-distance.pdf>.
28. National Association of City Transportation Officials. (2013). *Urban Street Design Guide*. New York, NY: Island Press.

29. Poole, B., Johnson, S., and Thomas, L. (December 2017). An Overview of Automated Enforcement Systems and Their Potential for Improving Pedestrian and Bicyclist Safety. Pedestrian and Bicycle Information Center. Chapel Hill, NC. Retrieved from: http://www.pedbikeinfo.org/cms/downloads/WhitePaper_AutomatedSafetyEnforcement_PBIC.pdf.
30. American Association of State Highway and Transportation Officials (2010). *Highway Safety Manual*. Retrieved from: <http://www.highwaysafetymanual.org/>.
31. Nilsson, G. (2004). Traffic safety dimensions and the Power Model to describe the effect of speed on safety. *Traffic Engineering*. Retrieved from: <https://lup.lub.lu.se/search/ws/files/4394446/1693353.pdf>.
32. Tefft, B.C. (2011). Impact Speed and a Pedestrian's Risk of Severe Injury or Death. AAA Foundation for Traffic Safety. Retrieved from: <https://aaaafoundation.org/impact-speed-pedestrians-risk-severe-injury-death/>.
33. National Highway Traffic Safety Administration. Fatality Analysis and Reporting System. Retrieved from: <https://www.nhtsa.gov/es/research-data/fatality-analysis-reporting-system-fars>.
34. National Highway Traffic Safety Administration (2018). Traffic Safety Facts: Pedestrians. Retrieved from: <https://crashstats.nhtsa.dot.gov/Api/Public/ViewPublication/812681>.
35. National Highway Traffic Safety Administration (2015). New Car Assessment Program (Docket No. NHTSA-2015-0119). Retrieved from: <https://www.federalregister.gov/documents/2015/12/16/2015-31323/new-car-assessment-program>.
36. Ulrich, Lawrence (12 September, 2019). S.U.V. vs. Sedan, and Detroit vs. the World, in a Fight for the Future. *The New York Times*. Retrieved from: <https://www.nytimes.com/2019/09/12/business/suv-sedan-detroit-fight.html>.
37. International Transport Forum (2019). Road Safety Annual Report 2019: Sweden. Retrieved from: <https://www.itf-oecd.org/sites/default/files/sweden-road-safety.pdf>.
38. US Department of Transportation, Bureau of Transportation Statistics (2014). Table 2-9: U.S. Air Carrier Safety Data [table]. Retrieved from: https://www.bts.gov/archive/publications/national_transportation_statistics/table_02_09.
39. National Civil Aviation Review Commission Archive
40. Josephs, L (13 Feb, 2019). The Last Fatal US Airline Crash Was a Decade Ago. Here's Why Our Skies are Safer. *CNBC*. Retrieved from: <https://www.cNBC.com/2019/02/13/colgan-air-crash-10-years-ago-reshaped-us-aviation-safety.html>.
41. Federal Highway Administration (2012). Methods and Practices for Setting Speed Limits: an Informational Report. Retrieved from: https://safety.fhwa.dot.gov/speedmgt/ref_mats/fhwas12004.
42. Hu, W. and J. Cicchino (2019). Lowering the speed limit from 30 to 25 mph in Boston: effects on vehicle speeds. Insurance Institute for Highway Safety. Retrieved from: <https://www.iihs.org/topics/bibliography/ref/2168>.
43. Fridman, L., Ling, R., Rothman, L. et al. (2020). Effect of reducing the posted speed limit to 30 km per hour on pedestrian motor vehicle collisions in Toronto, Canada - a quasi experimental, pre-post study. *BMC Public Health* 20, 56. Retrieved from: <https://doi.org/10.1186/s12889-019-8139-5>.
44. National Traffic Safety Board (25 July, 2017). Reducing Speeding-Related Crashes Involving Passenger Vehicles. Retrieved from: <https://www.ntsb.gov/safety/safety-studies/Documents/SS1701.pdf>.
45. Taylor, Brian D. and Yu Hong Hwang (30 June, 2020). Eighty-Five Percent Solution: Historical Look at Crowdsourcing Speed Limits and the Question of Safety. *Transportation Research Record*. Retrieved from: <https://doi.org/10.1177/0361198120928995>.
46. Federal Highway Administration (2012). Methods and Practices for Setting Speed Limits: an Informational Report. Retrieved from: https://safety.fhwa.dot.gov/speedmgt/ref_mats/fhwas12004.
47. California state law requires localities to evaluate 85th percentile speeds on a given street every seven years in order for the speed limit to be enforceable. According to the law, the city must identify the 85th percentile speed on the street and set speed limits to the nearest multiple of five.
48. California Highway Patrol. Statewide Integrated Traffic Records System. Retrieved from: <http://iswitr.chp.ca.gov/Reports/jsp/userLogin.jsp>.
49. Hu, W. and J. Cicchino (2019). Lowering the speed limit from 30 to 25 mph in Boston: effects on vehicle speeds. Insurance Institute for Highway Safety. Retrieved from: <https://www.iihs.org/topics/bibliography/ref/2168>.
50. Fridman, L., Ling, R., Rothman, L. et al. (2020). Effect of reducing the posted speed limit to 30 km per hour on pedestrian motor vehicle collisions in Toronto, Canada - a quasi experimental, pre-post study. *BMC Public Health* 20, 56. Retrieved from: <https://doi.org/10.1186/s12889-019-8139-5>.
51. Seattle DOT (July 2020). Speed Limit Case Studies. Retrieved from: https://www.seattle.gov/Documents/Departments/SDOT/VisionZero/SpeedLimit_CaseStudies_Report.pdf.
52. Federal Highway Administration. Curb Radius Reduction. Retrieved from: <https://safety.fhwa.dot.gov/saferjourney1/library/countermeasures/09.htm>.

SAN FRANCISCO

Photo: SFMTA





2

The Tools

Tools to Change Speed Limits

There are three primary tools for setting speed limits in urban areas.

Default Speed Limits*

Set default speed limits on many streets at once.

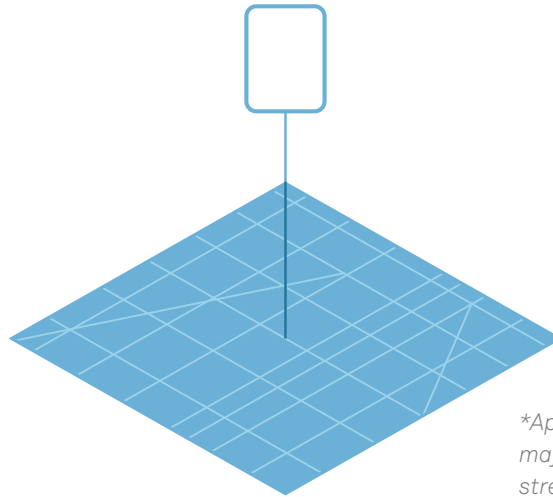

**Applicable on all streets—major, minor, and shared streets / alleys*

Slow Zones

Designate slow zones in sensitive areas.

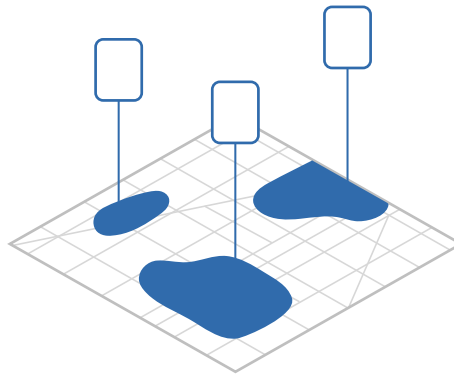

Corridor Speed Limits*

Set corridor speed limits on high priority major streets using a Safe Speed Study (see page 58).

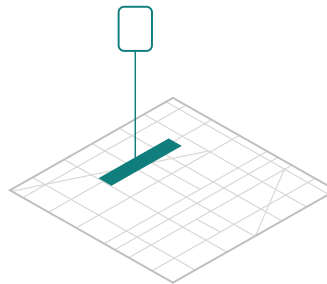

**Applicable on major streets only*

Authority to Change Speed Limits

The tool or combination of tools a city uses will depend on their authority to set speed limits. In some cases, state law already grants cities authority to set speed limits that comply with the guidance in *City Limits*. In others, state departments of transportation

or state legislation determines statewide speed limit setting requirements. In the absence of legislative or administrative requirements, city authority depends on engineering practice or law at the city level.

If the city has...

State-granted authority to lower speed limits through a locally-defined process or across many streets at once.

If possible, start by setting **citywide default speed limits** at 25 mph or below.
If desired or more politically feasible, set **default speed limits by category** of street (e.g., 25 mph on arterials, 20 mph on non-arterials).

Use a **Safe Speed Study** (see page 58) to lower speed limits below the citywide or category default on high-crash or otherwise high priority corridors. Consider using a Safe Speed Study to evaluate a batch of similar streets to lower speed limits on many streets of one type all at once (e.g., local streets).

Designate **slow zones**. Slow zones can be linear (along a street) or cover all streets within a specific neighborhood or business district.

If state or local legislation prevents any of the above, but conducting Safe Speed Studies and lowering default limits is desired, seek the authority to do so.

If the city has...

Limited authority to lower speed limits using a locally-defined process or across many streets at once.

Seek a written change in practice (leveraging *City Limits* may help).

Request that some streets be exempt from the 85th percentile requirement (e.g., **streets near schools or other sensitive areas like parks or neighborhood downtowns**).

Once the authority is established, see actions above.

Cities that have authority to set default speed limits have a number of options to improve safety on their streets. In some cities, setting the default limit citywide is the most effective approach. Citywide defaults provide a uniform, predictable limit that applies everywhere. They are relatively easy to implement and easy to explain to the public. Citywide limits can be combined with slow zones and with corridor limits on specific corridors to address conditions where a speed lower than the citywide default is necessary.

In cities where there is clear differentiation between major arterial streets and local or minor streets, cities may choose to set speeds by street type or category. Category-based limits allow cities to address significantly different street contexts but still create a predictable regulatory environment for drivers. Like citywide defaults, category-based defaults can be combined with slow zones and with corridor limits on specific streets.

In some states, cities do not have explicit authority to set their own default speed limits. These cities have different playbooks for aligning speed limits with their safety goals.

In states where the process for engineering studies is not codified in state law or practice, cities have asked for (or assumed) permission

to use a locally-defined process such as the Safe Speed Study method outlined on page 58, that is different from the 85th percentile method. In some cases, cities have used this same tactic to set default citywide or category-based speed limits by conducting “bulk studies” on a representative sample of similar streets in order to assess the appropriate speed for that category of street.

In the states where jurisdictions must set speed limits on most streets based on 85th percentile speeds, some cities have requested exemption from using the 85th percentile for specific streets (for example, streets identified in a high-injury network analysis). In these places, robust crash, fatality, and injury data collection is particularly important to make the case for exemptions.

In almost all states, cities have authority to create school slow zones. For example, in California, which codifies the use of the 85th percentile method to determine and enforce speed limits on streets across the state, the Vehicle Code allows all local jurisdictions to lower speeds in school zones that meet specific criteria. In 2019, Sacramento used this authority to reduce speed limits from 25 to 15 mph on 225 street segments across the city, even without the explicit authority to reduce default speeds citywide.



Photo: City of Sacramento

Combining Tools

Cities can combine these proactive speed management strategies to create safe conditions for their city.

EXAMPLE COMBINATION: CITY A

City A has explicit authority to set default speeds and has chosen to set a citywide default limit of 25 mph on all streets. In addition, they have identified a few high-crash corridors and have set 20 mph corridor limits on those streets to reduce fatalities and injuries. They also have established 20 mph slow zones in key areas around schools or parks to provide additional protection for children.

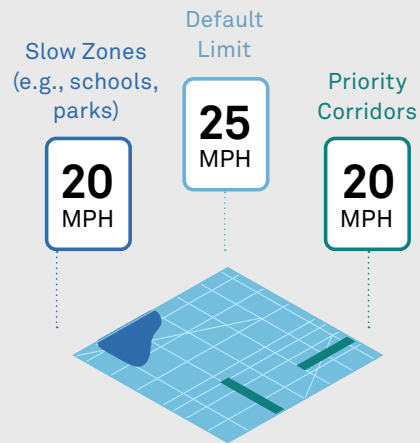

EXAMPLE COMBINATION: CITY B

City B has explicit authority to set default speed limits and has clear differentiation between major or arterial streets and minor or local streets. They have chosen to set category speed limits at 25 mph for arterials and 20 mph for non-arterials. Like City A, they may choose to also establish slow zones in key areas.

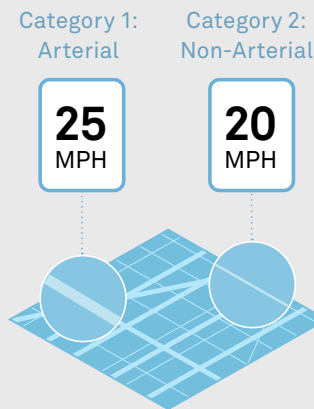

EXAMPLE COMBINATION: CITY C

City C does not have explicit authority to set default speeds. The state requires a speed study but does not lay out an explicit process. They have chosen to conduct a bulk engineering study and to use a locally-defined process for setting speeds by street category. At the same time, using authority to set speed limits on a case-by-case basis, they have conducted a Safe Speed Study to determine appropriate speed limits for a few priority corridors.



RECENT NOTABLE LEGISLATIVE CHANGES

Implementing the speed limit tools recommended in this guidance may require state-level legislative permission. A growing group of US states have passed legislation granting cities the flexibility to set safer speed limits. These supportive policies generally take one of two forms:

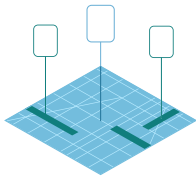

Authority to set context-sensitive speed limits using a locally-defined process.

Several states have passed laws that enable cities to create, adopt, and utilize an approach for setting urban speed limits that places safety as the top priority. Cities that leverage this authority do so in different ways, often by lowering default limits on some or all streets and also by updating local engineering guidance to redefine speed study procedures.

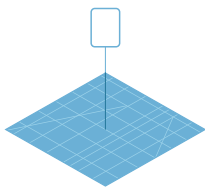

Authority to reduce default speed limits.

Some states have passed laws that explicitly allow cities to lower their default citywide speed limits (e.g., from 30 mph to 25 mph) or speed limits on a specific category of streets (e.g., “residential streets” at 20 mph).

OREGON

Oregon (Senate Bill 558) allows all cities in the state to establish a 20 mph speed limit on all non-arterial streets in residence districts under city jurisdiction. Rule 734-020-0015 allows the use of 50th percentile studies instead of 85th percentile studies on non-residential streets.



WASHINGTON STATE

Washington State has two pieces of enabling legislation that, together, allow cities to set safe speed limits:

RCW 46.61.415 allows local agencies to establish/alter maximum limits on local streets.

WAC 468-95-045 is a modification to the State MUTCD that provides local jurisdictions with considerations about what requirements they need to meet to revise the posted speed limit.

MINNESOTA

Minnesota Statute (Section 169.14, Subd. 5h - Speed limits on city streets) allows cities to establish speed limits on city streets based on the city's safety, engineering, and traffic analysis. Speed limits must be set in a consistent and understandable manner.

MASSACHUSETTS

Massachusetts (MGL c. 90 § 17C) allows "thickly settled" cities and towns to adopt a 25 mph default speed limit by ordinance for all streets unless otherwise posted. Cities and towns can also set 20 mph safety zones, which they can use their own criteria to create.

NEW YORK STATE

New York State Assembly Bill 10144/Senate Bill 7892 amended section 1642 of the Vehicle and Traffic Law to allow New York City to set a speed limit of 25 miles per hour, down from 30 mph, on streets that are not part of the State highway system. This was followed by NYC Local Law 54 of 2014, which enacted a citywide speed limit of 25 mph unless otherwise posted.

POLICY HURDLES

A city's ability to change speed limits is impacted by rules and practices around enforcement, signage, and design requirements.



Enforcement

A city's ability to enforce the posted speed limit depends on whether speed limits in the state are Absolute, Prima Facie, Basic Speed Law, or a combination of the three. When drivers are ticketed in a state with absolute speed limits, the ticket will typically stand on face value. In states with prima facie, or presumed, speed limits, drivers can contest tickets in court on the basis that their speed was safe for the conditions. In basic speed law states, drivers are required only to travel at a safe speed, regardless of the posted speed limit. A growing body of evidence shows that drivers respond to posted speed limits even without changes to enforcement; cities may want to make speed limit changes even when enforcement is difficult.

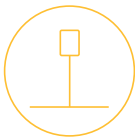

Signage

In some states, a city must install a sign on every block if the posted speed limit is anything other than the citywide default. This is feasible when the city lowers the limit on a small number of segments, but becomes prohibitively expensive at a large scale (e.g., across all residential streets).



Design

In some states, cities must implement physical design changes to streets in order to justify lower speed limits. Requiring engineering changes before cities can change the posted limit can make it difficult for cities to change speed limits on a large number of streets because of the cost. Other cities must reduce speed limits before they can make design changes, since the design speed is set in relation to the posted speed on a given street.

Case Studies in Lowering Speed Limits



Recognizing the importance of lowering speed limits to improve safety, a number of cities have successfully amended their speed limits in recent years. The four cities highlighted below present interesting lessons learned for other municipalities looking to lower speed limits on their streets.

SEATTLE

In 2016, Seattle lowered its default speed limit from 25 to 20 mph on neighborhood streets and from 30 to 25 mph on arterials. The City has also begun to reduce speed limits within urban villages, where lots of people walk, bike, drive and use transit.

Resources: [Seattle DOT Speed Limits Website](#), [Seattle DOT Blog](#)

NEW YORK CITY

In 2014, New York City lowered its default citywide speed limit from 30 to 25 mph, which complemented a Neighborhood Slow Zone program implemented in 2011.

Resources: [2014 NYC Vision Zero Action Plan](#), [Borough Pedestrian Safety Action Plans](#), [Families for Safe Streets](#)

CAMBRIDGE

In 2016, the City of Cambridge lowered its default citywide speed limit from 30 to 25 mph. In the years since, Cambridge has leveraged authority to further reduce speed limits to 20 mph in Safety Zones to reduce speed limits to 20 mph on nearly every street in the city.

Resources: [City of Cambridge Speed Limits Website](#)

PORTLAND

In 2018, Portland lowered the default speed limit on residential streets from 25 mph to 20 mph. This change complements 20 mph speed limits in business districts.

Resources: [Portland Bureau of Transportation Speed Limits Website](#), [50th Percentile Allowance on Non-Residential Roads](#)

CASE STUDY

SEATTLE



Photo: City of Seattle

In October 2016, the Seattle City Council passed an ordinance to lower the **default speed limit** from 25 to 20 mph on 1,250 miles of neighborhood streets and the **default speed limit** from 30 to 25 mph on arterials. This change was the result of a months-long legislative process initiated by Seattle DOT leadership.

To build their case for lower speed limits, Seattle DOT (SDOT) staff compiled two documents. The first was a detailed history of the city's 1934 decision to reduce speed limits to 25 mph on arterials and 20 mph on residential streets, and their 1948 decision to raise the default maximum speed across the city from 25 to 30 mph. The second was a data-based justification for lower speed limits in 2016. In this document, SDOT made the case that the built environment, the city's Vision Zero commitment, and recent mode shift away from driving and toward walking, biking, and taking transit all signaled a need for lower, safer speed limits. SDOT also included speed and safety data from all of their recent Vision Zero pilot projects.

In November 2016, the new law went into effect. This campaign was a success in large part because of the data that SDOT used to

support their request. SDOT also included a variety of stakeholders during the process—the transportation director, a city council member, a lawyer from the law department, the city traffic engineer, and a public engagement specialist.

Since the law passed, SDOT has built on the momentum of reducing speed limits across the city to leverage existing state-level authority to reduce speed limits on **3 high crash corridors** using a context-sensitive engineering study. They are also leveraging both of these tools to reduce speed limits at a neighborhood scale in particular zones.

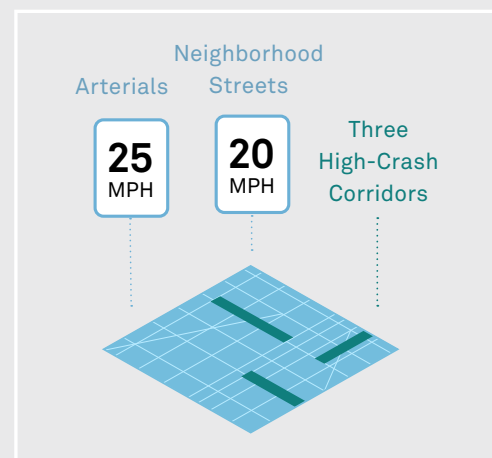

CASE STUDY

NEW YORK CITY



New York City has worked for over a decade on comprehensively reducing speeds on streets across its five boroughs. In 2011, the City installed its first **Neighborhood Slow Zone**: a program that revamps small (about ¼ square mile) residential areas with low traffic volumes and minimal through traffic, with 20 mph on-street markings, signs, speed humps, and other traffic calming treatments. This program quickly expanded to over two dozen neighborhoods, increasingly demonstrating the large demand for safer streets across the city.

In 2013, family members of people killed in traffic crashes in New York joined with City Council members and local agencies to petition the State Legislature to reduce speed limits. At the time, the citywide speed limit was 30 mph, the lowest allowed by state law. The campaign hit political hurdles and the State took no action.

The next year, New York City rolled out its Vision Zero Action Plan, which called for City Hall to lead a campaign to reduce the **citywide speed limit** to 25 mph.

With the combined advocacy of a years-long campaign by local safe streets advocates, as well as sustained pressure from the Mayor's Office and city agencies, the state legislature

passed a new bill in June 2014 authorizing New York City to lower its citywide speed limit. The City promptly took action, and a new **citywide speed limit** of 25 mph went into effect in November of the same year.

In the same legislative session, the State Legislature also granted New York City permission to establish an automated speed enforcement program with a limited number of cameras located in school zones. The program was successful, with speeds lowered by an average of over 60 percent in camera locations. In 2019, the City obtained new authority to expand this program more than five-fold, from 140 to 750 active zones.

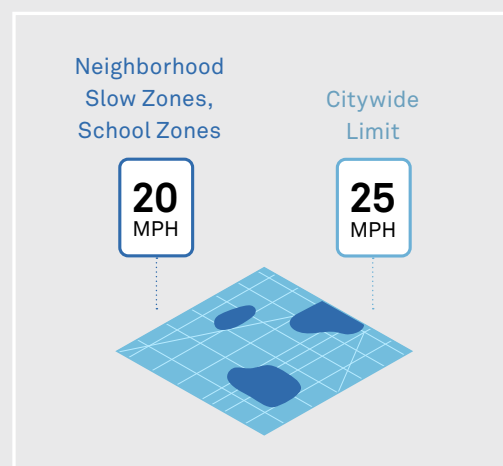

CASE STUDY

CAMBRIDGE



Photo: City of Cambridge

In 2016, the City of Cambridge lowered speed limits to 25 mph **citywide** and began implementing 20 mph **safety zones** in 2018. Cambridge—along with other cities and towns in Massachusetts—have the right to set speed limits for “thickly settled” areas under the state’s 2016 Municipal Modernization Act.

Prior to this reform, the default speed limit in thickly settled areas was 30 mph and required a speed study to change a speed limit. But when a new Governor was elected in 2015, his office asked all municipalities how the legislature could update state regulations to make cities more effective. Among the asks was a request for greater local authority in setting speed limits.

The law allows any city or town to adopt citywide default limits of 25 mph for areas that meet the definition of thickly settled (homes or businesses spaced 200’ or less apart) and safety zone limits of 20 mph with local government approval. The definition of safety zone is broad, taking into account the

presence of vulnerable users, schools, parks, and senior centers, among other factors. Implementation of a Safety Zone on streets under municipal control does not require State authorization.

In 2019, using this authority, the City of Cambridge embarked on an effort to reduce speed limits to 20 mph on most streets. At the time of publication, Cambridge has successfully reduced speed limits to 20 mph on the majority of streets in the city.

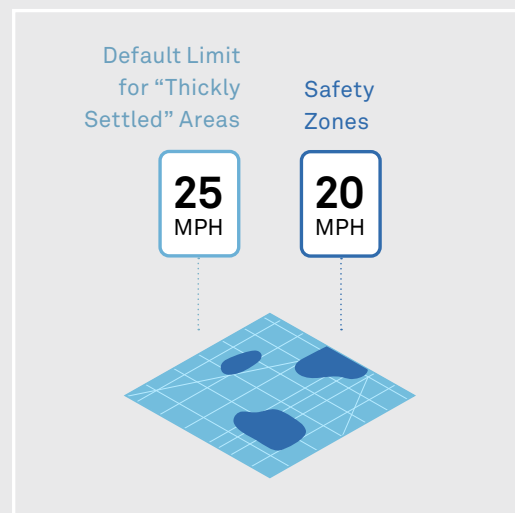

CASE STUDY

PORTLAND



In 2018, Portland City Council approved an ordinance that lowered the speed limit on **all residential streets** to 20 mph, a change that resulted in reductions on 70 percent of the city's street network.

Oregon state law also allows the city to implement a 20 mph speed limit in **business districts** and to lower speed limits on specific non-residential streets pending approval from Oregon DOT in each case.

In Portland, there are 228 miles of non-residential arterials with speed limits between 35 and 45 mph where most road deaths occur. Effective May 1, 2020, the Oregon DOT began using a revised speed setting methodology for streets like these in urban areas that weighs 50th instead of 85th percentile speeds, and that better accounts for the presence of exposed road users, street design, and land use characteristics. This important change came after years of coordination between City of Portland staff and Oregon DOT staff to develop a revised methodology for determining speed limits on non-residential streets.

After a speed limit change is approved, but before installing new signs, City of Portland staff notify neighborhood residents about the speed limit changes, along with officials at the local transit agency, which notifies their operators.

Where possible, City of Portland staff work to coordinate speed limit reductions with street redesigns, such as road reorganizations. However, Portland frequently reduces speed limits on streets without any expected near-term changes in street design or enforcement.

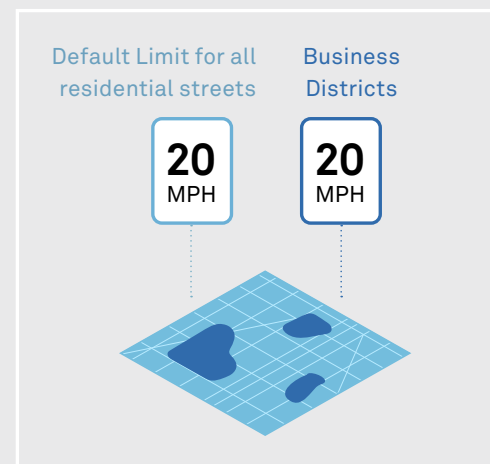



**SPEED
LIMIT
25**

SPEED

35



3

The Right Speed Limits

PORTLAND

Photo: City of Portland

Recommended Speed Limits

This document recommends maximum speed limits of 10-25 miles per hour for most city streets, increasing to 35 mph only in select, limited cases. The maximum recommended speed limit for any shared street or alley is 10 mph, and the maximum recommended speed limit for any minor street is 20 mph. The maximum recommended speed limits are based primarily on speeds that minimize risk to pedestrians and cyclists.⁵²

SHARED STREETS & ALLEYS

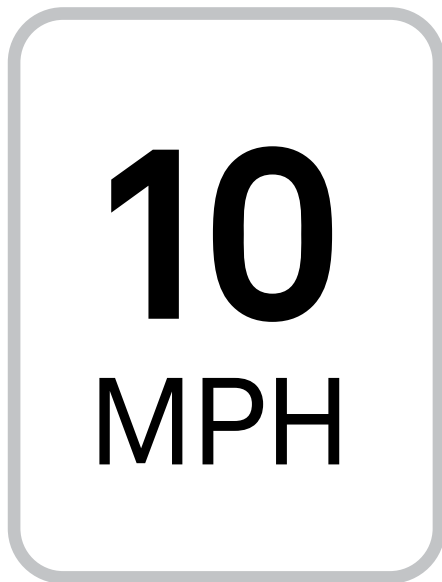

MINOR STREETS



MAJOR STREETS

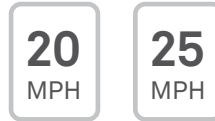
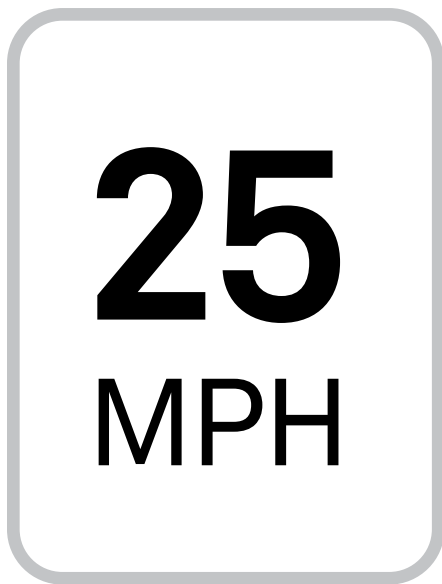

On major streets, where conditions vary widely, cities can conduct a Safe Speed Study to determine the safest maximum speed limit (see page 58). In urban areas, a Safe Speed Study will most often result in a recommended maximum speed limit of 20 or 25 mph for major streets.



For streets that have well-protected places for people to walk and bike, and that are in low density areas with primarily manufacturing and residential uses, cities may find that a 30 or even 35 mph speed limit is appropriate. However, these higher speed limits should be used sparingly and only in cases where safe conditions can be met.



BOULDER

Photo: Kevin J. Krizek, Professor,
University of Colorado Boulder

Default Speed Limits

Applicable on all streets—major, minor, and shared streets / alleys

Default Speed Limits

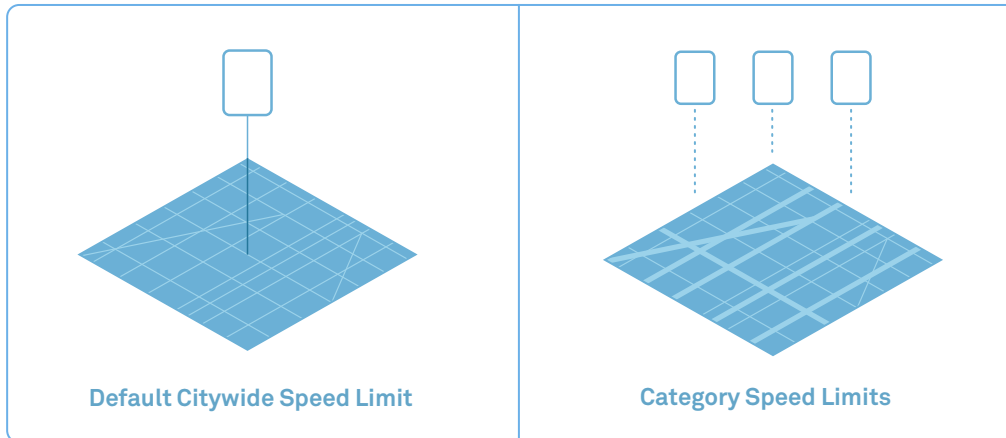

Cities have two options for setting default speed limits: **citywide** or **by street category** (e.g., major, minor, alley).

Citywide speed limits are generally easier to implement and may be easier for drivers to follow. However, in cities where there is clear differentiation between major arterial streets and local or minor streets, setting speed limits based on category of street can sometimes allow cities to lower speed limits

on a large number of streets below what would be allowable citywide (i.e., 20 mph on minor streets vs. 25 mph citywide).

If cities have the authority to set default speed limits, they should decide whether to implement citywide limits or category limits based on what makes the most sense given the local conditions.

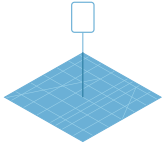

Citywide Speed Limits

Default citywide speed limits, or “unless otherwise posted” speed limits, provide a jurisdiction-wide speed limit in effect at all times and on all streets, except where a different speed limit sign is in place. These are generally the easiest speed limits to implement, and are usually enacted through law.

Setting or lowering default citywide speed limits is an inexpensive, scalable way to quickly improve safety outcomes, and establish a basis for larger safety gains. Default citywide limits also provide consistent expectations and messages about speed across the jurisdiction, which is easy for drivers to follow.

Recommended default citywide speed limit:



The Boston Globe

Boston is set to lower its speed limit in Jan.

By Andy Rosen Globe Staff, November 30, 2016, 4:45 p.m.



City of Atlanta reduces speed limit to 25 mph



Top: The City of Boston lowered the default citywide speed limit to 25 mph in January 2017.

Bottom: In April 2020, the City of Atlanta voted to lower the default citywide speed limit to 25 mph.

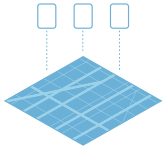

Category Speed Limits

Category speed limits apply speed limits to specific categories of streets based on broad classes, such as major streets, minor streets, and alleys, allowing cities to set a small number of speed limits that apply to nearly all streets. This simple categorization scheme allows cities to quickly adjust speed limits on most streets, and frees up resources to focus on high-crash corridors or

places where site-by-site analysis is necessary. Depending on the city, setting speed limits by category might be more politically feasible than setting a default citywide limit. If setting categories based on major and minor streets, practitioners should develop definitions for these streets that are easy to use based on existing local data.

MAJOR
STREETS:

25
MPH

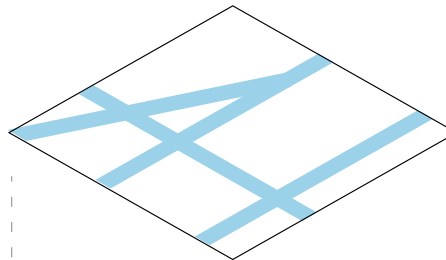

MINOR
STREETS:

20
MPH

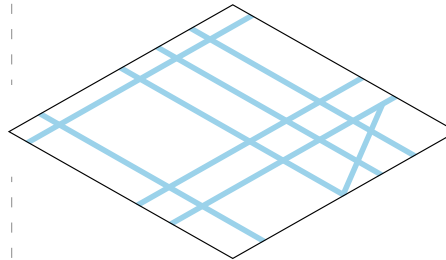

SHARED
STREETS
& ALLEYS:

10
MPH

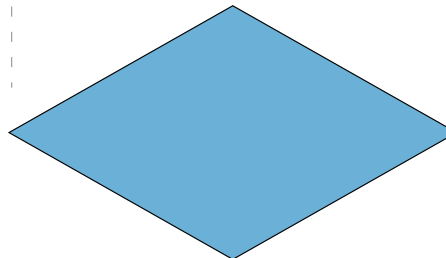
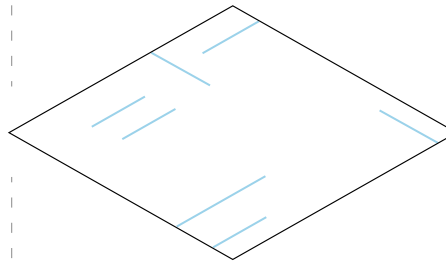

MAJOR STREETS

A 25 mph speed limit on urban multi-lane streets has demonstrable safety benefits for all users.^{53, 54} Major streets feature a combination of high motor vehicle traffic volume, signalization of major intersections, and an inherently multimodal street environment.

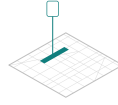

If unable to set a category speed limit for *all* major streets, cities should conduct a Safe Speed Study for high-priority major streets on an individual basis. See Safe Speed Study section on page 58.

Major streets are often characterized by:

- › Signalized intersections
- › Few, if any, all-way stop intersections
- › At least two formal (marked) motor vehicle traffic lanes, and usually more
- › Frequent transit stops
- › Moderate to high motor vehicle volumes
- › Multi-lane downtown one-way and downtown two-way streets, as well as many neighborhood main streets, multi-way boulevards, and transit boulevards as described in the NACTO *Urban Street Design Guide*

Recommended category speed limit for Major Streets:

**25
MPH**

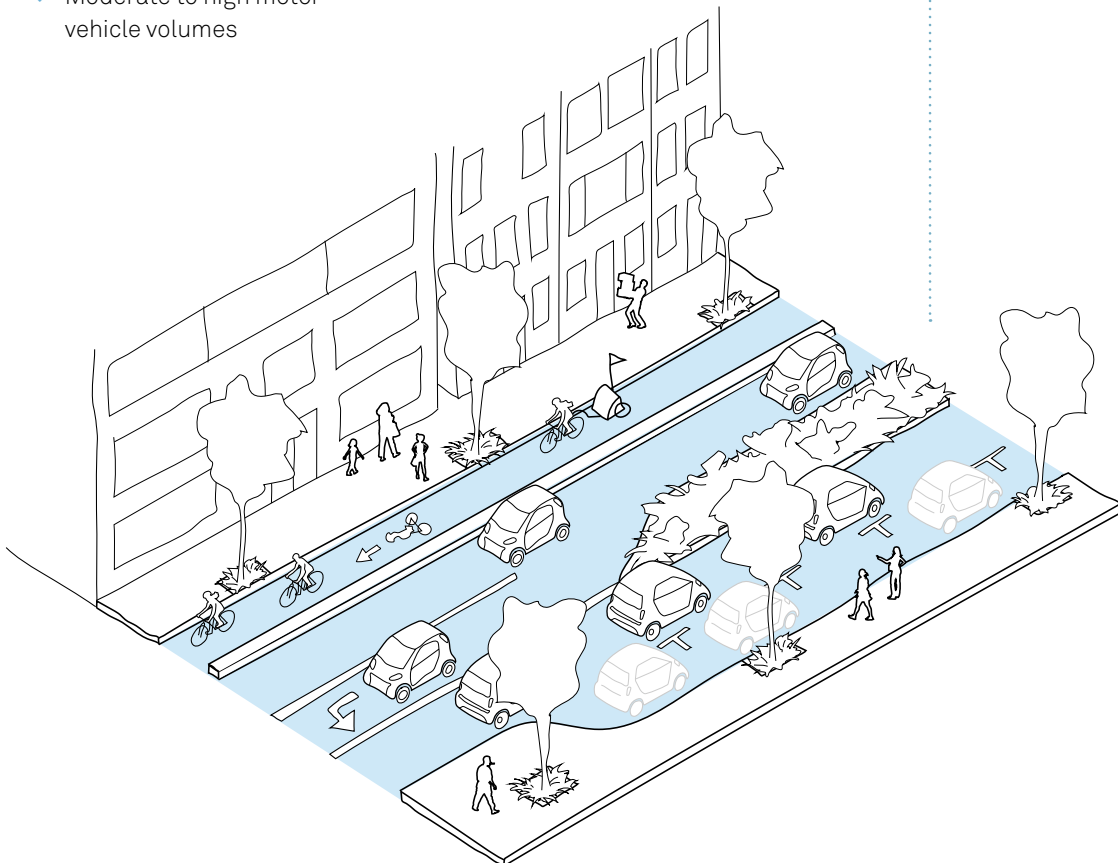

MINOR STREETS

A 20 mph speed limit on minor streets supports safe movement and contextually appropriate design on the majority of city streets.⁵⁵ Since minor streets tend to have either very low volumes or operate at the speed of the most cautious driver, cities can apply a category speed limit to minor streets without detailed review of street characteristics.

Minor streets include physically small streets where low speeds are often already present, as well as low-vehicle-volume streets with few or no transit stops.

Minor streets are often characterized by:

- A single moving vehicle lane (one- or two-way)
- Two moving vehicle lanes but fewer than 6,000 vehicles per day
- A “minor” or “local” definition in a citywide street typology or street plan
- Stop controls, all-way stop controls, or yield-controls at multiple intersections
- Yield streets, neighborhood streets, some residential boulevards, one-lane downtown one-way and two-lane downtown two-way streets as described in the NACTO *Urban Street Design Guide*
- Lateral, service, or access roadways along multiway boulevards

Recommended category speed limit for Minor Streets:

**20
MPH**

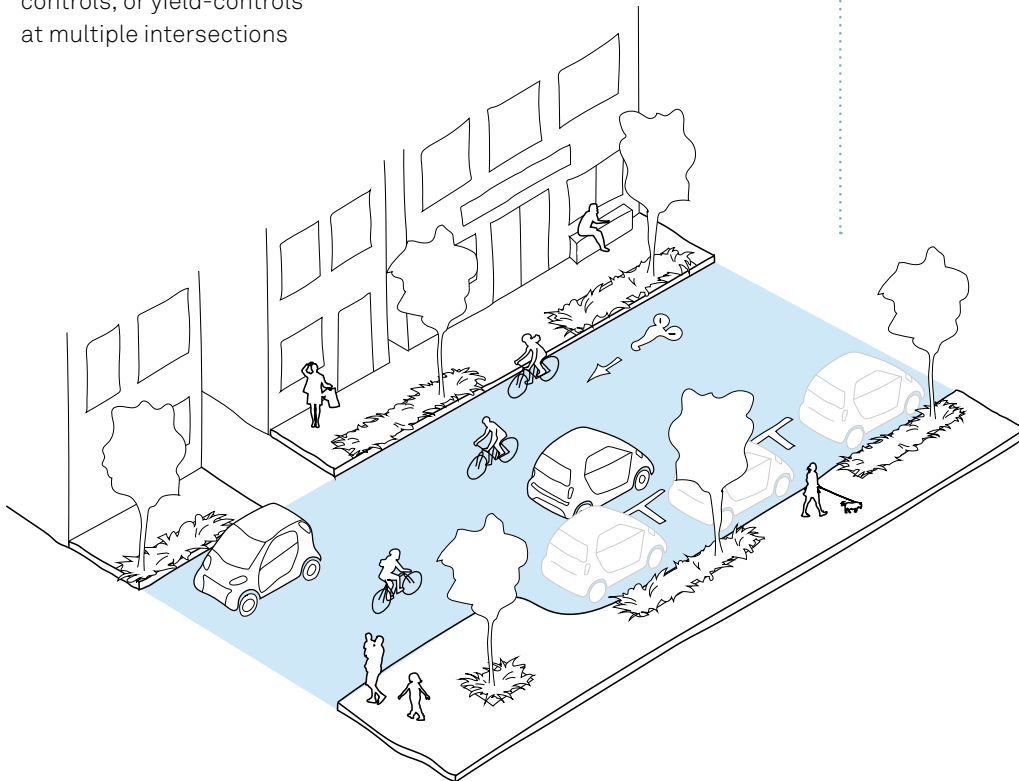

SHARED STREETS & ALLEYS

Shared street surfaces where people are expected to walk in front of motor vehicles or against oncoming motor vehicles call for the lowest category speed limits. Especially in places where large vehicles routinely enter shared street spaces, speed limits even lower than the recommended 10 mph may be advisable.

A 10 mph speed limit is also appropriate for dead ends, laneways, some service/parking/access roads along multiway boulevards, and other streets where walking, playing, or public space activities are expected in the roadway.

**Recommended
category speed
limit for Shared
Streets & Alleys:**

**10
MPH**

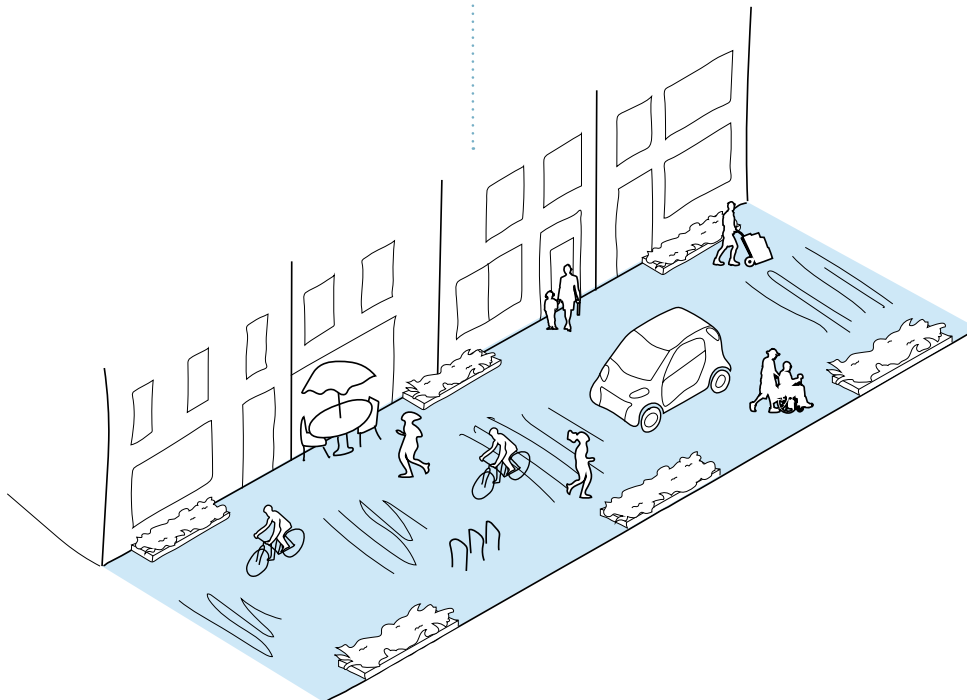



SPEED
LIMIT
20 is Plenty

seattle.gov/visionzero

VISION ZERO

 **SDOT**
Seattle Department of Transportation

SEATTLE

Photo: City of Seattle



Defining Slow Zones

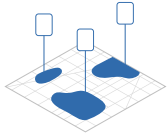

Defining Slow Zones

Slow zones are specifically designated areas with slower speeds than otherwise similar streets in the same jurisdiction. Neighborhood-scale or site-specific zones are useful for addressing high-priority areas such as areas with

elevated collision rates or sensitive land uses such as schools or parks. Cities should create slow zones based on their own location-specific needs, but several types of slow zones are relatively common.



Photo: City of New York

School, Park, & Senior Areas

School, park, and senior area slow zones, as well as slow zones in other sensitive environments, encourage slow speeds in areas with a high concentration of people who are at special risk on the street. In these zones, speeds on major streets may be set as low as 15 mph. Time-of-day school speed limits can be used when the school is an uncharacteristically sensitive place compared with the rest of the street (e.g., a 15 mph limit is appropriate near a school on a major street that would otherwise default to 25 mph).

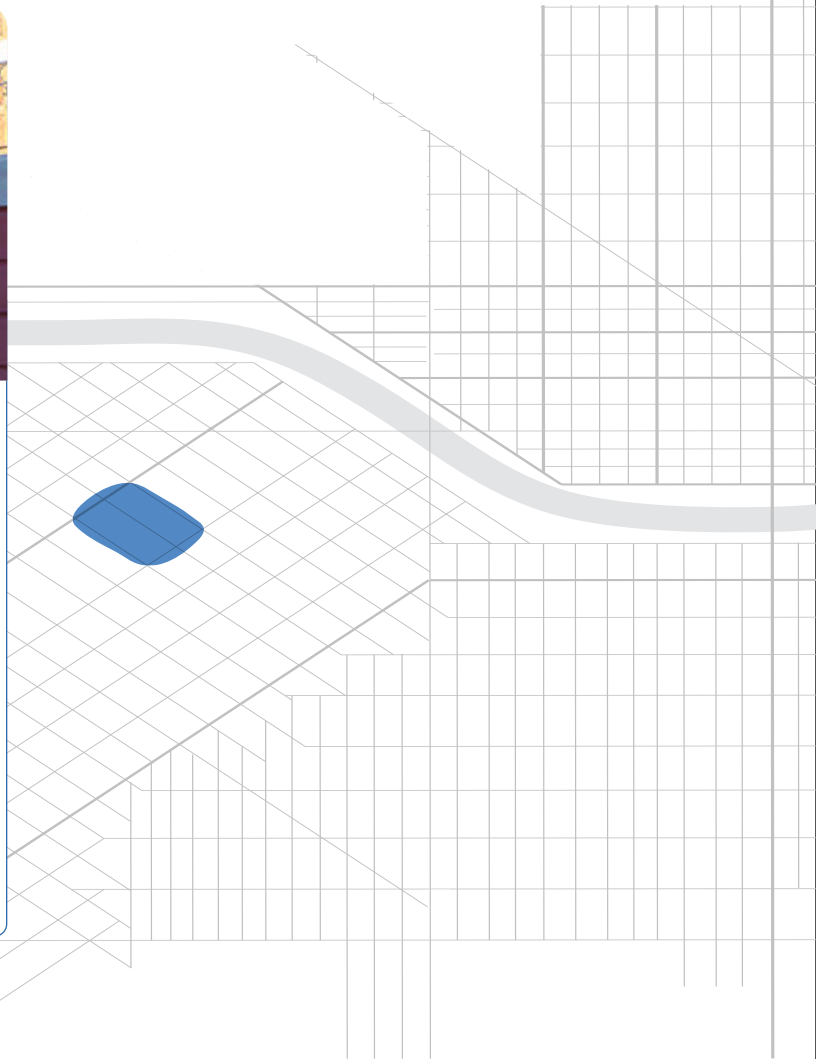



Photo: City of Boston

Neighborhoods & Districts

Neighborhood slow zones and district speed zones are implemented at a neighborhood-wide or district-wide scale. Sometimes these are also called Safety Zones or Neighborhood 20 mph Zones. The recommended maximum speed limit for these zones is 20 mph, and they are often accompanied by either vertical traffic calming elements or specific markings.



Photo: Scott Kocher, City of Portland

Downtown

Downtown slow zones or safety zones are a form of district speed zones in high density downtown areas or neighborhood downtowns where conflict is normal and should be expected, even on major streets. The recommended maximum speed limit for these zones is 20 mph.



SAN FRANCISCO

Photo: SFMTA

Corridor Speed Limits

Applicable on major streets *only*

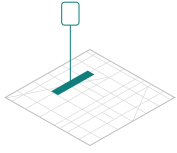

Setting Speeds on Major Street Corridors

In some jurisdictions or on certain types of streets, cities may be required to conduct a speed study to determine the appropriate speed limit. In other places, cities may want to conduct a speed study to justify lower speed limits on high-crash corridors below what they are typically authorized to do through citywide or category mechanisms. In these cases, a Safe Speed Study is the appropriate tool to use.

Safe Speed Studies are a contextually sensitive tool for determining the correct speed limit for a major street corridor. The Safe Speed Study methodology analyzes conflict density and activity level, among other contextual factors, to determine the speed limit that will best minimize the risk of a person being killed or seriously injured. In general, high conflict, high activity streets

will require lower speed limits since the risk of a crash is high, while somewhat higher speeds can be tolerated on low conflict, low activity streets.⁵⁶

This section provides step-by-step guidance for conducting a Safe Speed Study on major street corridors. Safe Speed Studies should be used whenever a corridor speed study is required or desired and should be used in lieu of a percentile-based speed study.

To minimize the risk of a person being killed or seriously injured, cities should set speeds based on conflict density and activity level.



Photo: The Observer

How to Conduct a Safe Speed Study

There are four main components of a Safe Speed Study: collect data, analyze existing conditions, determine how to manage speeds down, and evaluate changes.

1 ● ○ ○ ○ Collect Before Data

Begin by collecting data about corridor conditions and crash history.

2 ● ● ○ ○ Analyze Existing Conditions

Analyze the corridor, focusing on the frequency of conflict and the amount of activity, and use the risk matrix on page 63 to determine the appropriate posted speed.

3 ● ● ● ○ Determine Best Option for Speed Management

Decide on the best option to manage speeds along the corridor using the decision tree on page 73.

4 ● ● ● ● Conduct an Evaluation

Evaluate speed management efforts through pre- and post-implementation data evaluation.

A Safe Speed Study should be conducted for the longest relevant segment of a street corridor. If a corridor changes significantly at a specific point, it can be divided into two or more segments.

Cities should avoid studying every block or every segment of a long corridor. Instead, cities should identify key locations for study and select the lowest practicable speed limit for the longer segment to manage both safety and legibility along the corridor.⁵⁷

A Safe Speed Study can also be performed for a large area or district. As with corridor studies, it is not necessary to record data on every block within the district. Instead, district-wide corridor speed limits can be set based on an assessment of a typical street within that district. In most cases, selecting 20 to 30 representative blocks at random will provide a reasonable sample of speeds for a category of similar streets, regardless of the size of the city.

1 ● ○ ○ ○

Collect Before Data

Collecting before/after data allows cities to better understand the need for changes and helps them to more clearly communicate project benefits and impacts to the public. Before implementing a speed management project or policy, cities should collect and evaluate data such as existing speeds, speeding opportunities, fatal and serious injury crashes, and conflict counts. More information about collecting and using data to improve safety is provided on page 82.

Each type of data provides different information. For example, information on speeding opportunities and conflict counts indicate the potential for a serious crash while a history of serious or fatal crashes indicates an existing problem that could be resolved with lower speeds. Before/after evaluation data is needed for understanding the conditions on a corridor but is not essential to determine what the new speed limit should be.

When using crash report forms to assess the issues on a corridor, it is important to remember that these reports are often inconsistent. The US does not have a uniform crash reporting form or protocol across jurisdictions. In addition, most crash report forms lack a way to record the secondary crash factors, such as speed or road design, that contribute to the incident.

According to the National Highway Traffic Safety Administration, speed is a major factor in 25% of traffic fatalities.⁵⁸ In 2018, eight percent of fatal crashes were primarily due to speeds being “too fast for conditions,” and the other 17% were due to some other type of speed-related issue. However, there is evidence suggesting that speed may be an even larger contributor to the rising US fatality rate than the national statistics show.

DATA TYPES

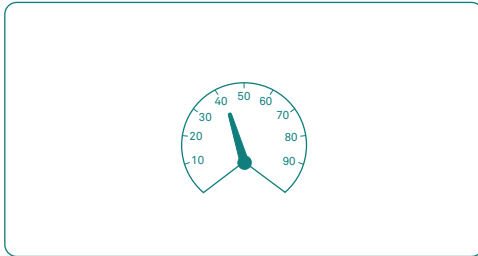

Existing speeds: how fast drivers are traveling on the street. Cities should evaluate a range of metrics, including high-end speeding, speeding, standard deviation, median speed, and 85th percentile speed (see page 85).

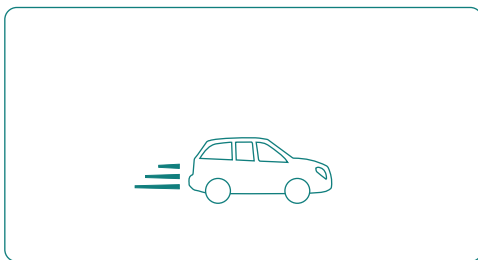

Speeding opportunities: locations where drivers are comfortable exceeding a safe speed because of the design and environment of the street.



Fatal and serious injury crashes: a five-year history (if possible) of all crashes that resulted in a fatality or a serious injury, including the location of the crash and the circumstances of the crash (e.g., left turning vehicle, sideswipe, etc.).

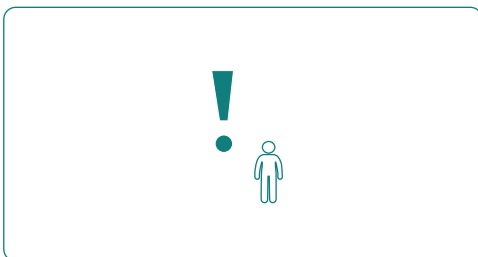

Conflict counts: how often two people or vehicles are on a collision course and must take evasive action to prevent a crash.

2 ●●○○

Analyze Existing Conditions

When determining a safe speed limit for a major street, there are two primary considerations:



CONFLICT DENSITY

How frequently potential conflicts arise on a given street

A conflict exists when a normal interaction, such as crossing the street while turning vehicles yield, is so close and at such a speed that a crash would happen unless sudden action is taken. In urban conditions, this is usually a factor of how separated modes are, and what the crossing demand is.



ACTIVITY LEVEL

How active a street currently is or is expected to be

Crashes that cause fatalities or serious injuries are generally the result of conflicts happening at speeds that are too high for a human body to endure. Therefore, streets with a greater number of potentially serious conflicts and a higher level of activity should have lower speed limits.

RISK MATRIX: CONFLICT DENSITY AND ACTIVITY LEVEL

The framework below summarizes a method for determining maximum safe speed limits based on the density of conflict points and level of activity on a major street. On urban streets where cities are required to conduct a study to determine the correct speed limit, they should use this framework instead of

the passive 85th percentile speed study that the *MUTCD* recommends for highways.

The following pages provide thresholds for each activity and conflict density level, and apply these thresholds to example streets in North America.

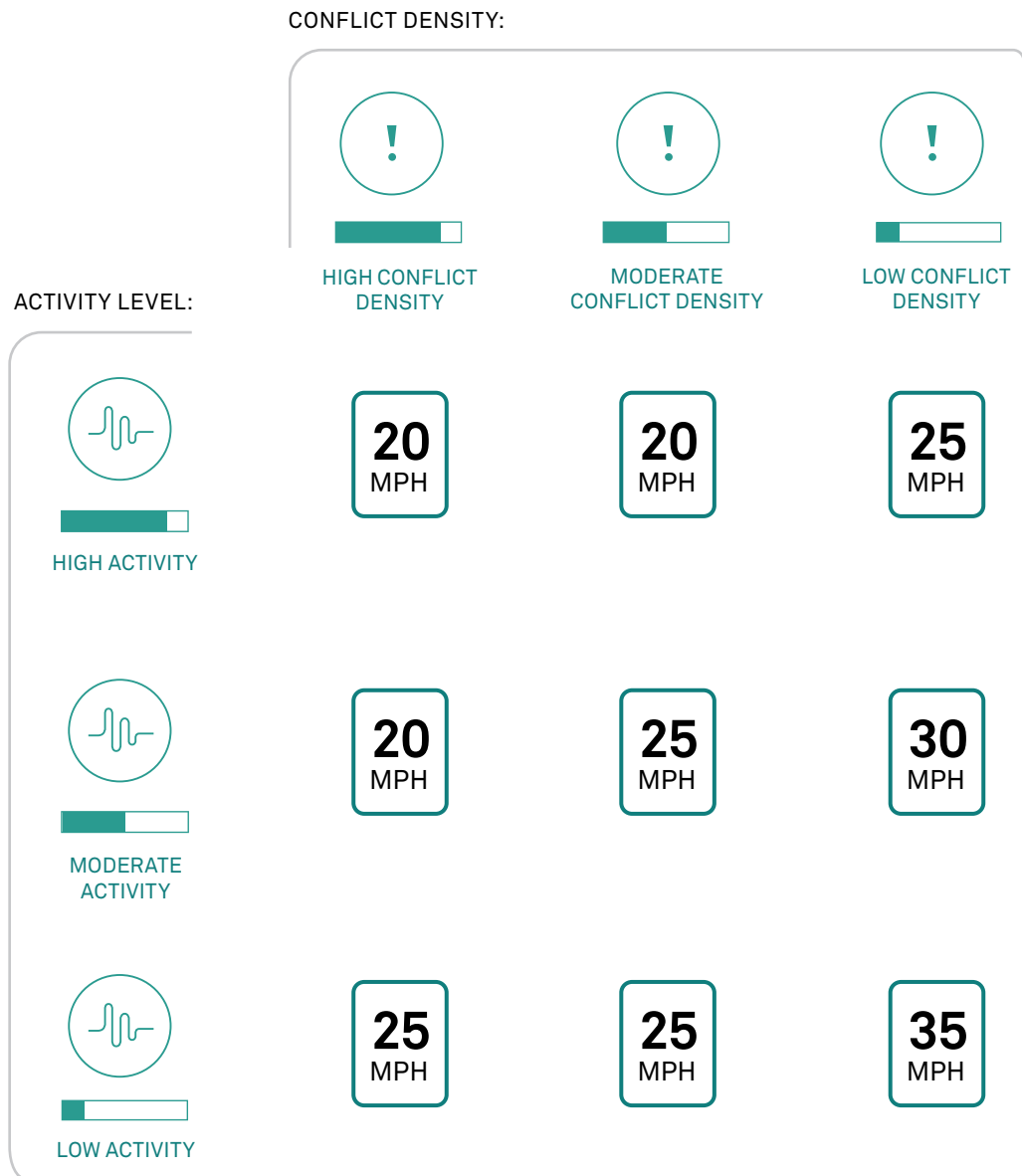



CONFLICT DENSITY

Two primary factors determine how frequently potential conflicts between motor vehicles and people walking or bicycling arise on the street:

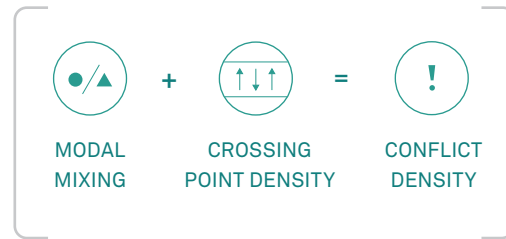

MODAL MIXING

How much physical separation the street offers people walking, biking, and rolling along the street.

Typical **modal separation** patterns in urban contexts:

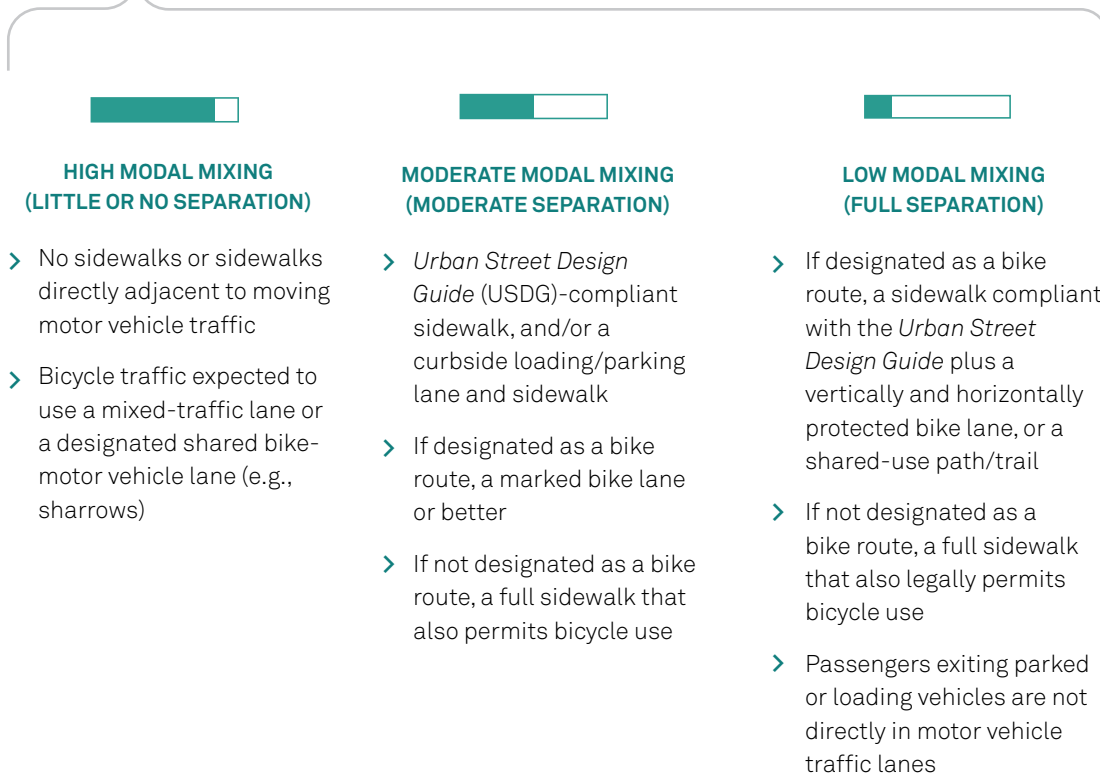

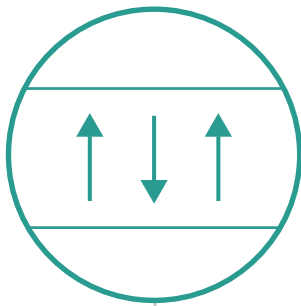

CROSSING POINT DENSITY

How closely spaced intersections and other crossing locations are.

Typical **crossing point density** patterns in urban contexts:



HIGH DENSITY OF CROSSING POINTS for bicyclists, pedestrians, and motor vehicles

- > 3 or more “through” or “X” intersections (signalized or unsignalized), “T” intersections, driveways, curb cuts, or other crossing points per ¼ mile



MODERATE DENSITY OF CROSSING POINTS for bicyclists, pedestrians, and motor vehicles

- > 1-3 “through” or “X” intersections (signalized or unsignalized), “T” intersections, driveways, curb cuts, or other crossing points per ¼ mile



LOW DENSITY OF CROSSING POINTS for bicyclists, pedestrians, and motor vehicles

- > No “through” or “X” intersections (signalized or unsignalized), “T” intersections, driveways, curb cuts, or other crossing points per ¼ mile



APPLYING A CONFLICT DENSITY ANALYSIS ON EXAMPLE STREETS

Example Street A



Photo: NACTO



Minimal separation for cyclists: **HIGH MODAL MIXING**

+



Short blocks: **HIGH CROSSING POINT DENSITY**

=



HIGH CONFLICT DENSITY

Example Street B



Photo: Google



Minimal separation for cyclists: **HIGH MODAL MIXING**

+



Short blocks: **HIGH CROSSING POINT DENSITY**

=



HIGH CONFLICT DENSITY

*Page TK contains a set of checklists that practitioners can use to apply these concepts in practice to determine the safest speed limits for their streets.

Example Street C



Photo: NACTO



USDG-compliant sidewalk:
MODERATE MODAL MIXING

+



Moderate length blocks: MODERATE
CROSSING POINT DENSITY

=



MODERATE
CONFLICT DENSITY

Example Street D



Photo: Google



Full separation for cyclists
and pedestrians on multi-use
path: LOW MODAL MIXING

+



Very low demand for vehicular
or pedestrian crossing: LOW
CROSSING POINT DENSITY

=



LOW CONFLICT
DENSITY



ACTIVITY LEVEL & LAND USE

Activity levels influence the rate at which potential conflicts occur at any given site on the street. Activity can be measured directly where data is available, or through land use and transportation network proxies. Most urban streets are either high activity or moderate activity. This guidance intentionally does not set quantitative activity thresholds. Practitioners seeking to utilize quantitative thresholds should determine and set those based on what works well in their cities and what goals they are trying to meet.



Typical **activity** conditions and scenarios include:



HIGH ACTIVITY

Streets with lots of existing or expected pedestrian activity, active public spaces, important bike routes or planned bike routes, high curbside demand, and high density of transit stops

- > Downtown / Central Business Districts
- > Retail corridors
- > High density residential and commercial streets



MODERATE ACTIVITY

Streets with moderate existing or expected pedestrian activity, moderately used public spaces, some existing or expected bike traffic, frequent driveways, curbside parking/loading, and moderate density of transit stops

- > Moderate density residential and commercial streets
- > Streets with light retail activity
- > Mixed use corridors



LOW ACTIVITY

Streets with minimal expected pedestrian volumes, minimal expected or planned bike activity, low curbside demand, and few, if any, transit stops

- > Low density industrial and residential streets



APPLYING AN ACTIVITY LEVEL ANALYSIS ON EXAMPLE STREETS

Example Street A



Downtown context with high-density residential, commercial, and retail land uses along both sides of the corridor

=



HIGH ACTIVITY

Example Street B



Mixed used corridor with moderate density commercial land uses

=



MODERATE ACTIVITY



APPLYING AN ACTIVITY LEVEL ANALYSIS (CONTINUED...)

Example Street C



Photo: NACTO

Moderate density residential street

=



MODERATE ACTIVITY

Example Street D



Photo: Google

Low density manufacturing and commercial land uses on both sides of the corridor

=



LOW ACTIVITY



COMBINING ANALYSES ON EXAMPLE STREETS

High activity streets with a high potential for conflict are the riskiest and command the lowest speed limits. Meanwhile, low activity streets with a relatively low potential for conflict may allow for slightly higher speed limits.

Example Street A



HIGH CONFLICT DENSITY + **HIGH ACTIVITY** = **20 MPH**

Example Street B



HIGH CONFLICT DENSITY + **MODERATE ACTIVITY** = **20 MPH**

Example Street C



MODERATE CONFLICT DENSITY + **MODERATE ACTIVITY** = **25 MPH**

Example Street D



LOW CONFLICT DENSITY + **LOW ACTIVITY** = **up to 35 MPH**

3 ● ● ● ○

Determine Best Option for Speed Management

The Safe Speed Study will identify the recommended speed limit for a particular street (or category of street). This recommended speed limit will either be lower than or the same as the existing posted speed limit. Cities should collect

“before” data about the street (described in “Collect Before Data” on page 60) to determine the street’s current operating speeds. One of four situations will be apparent after conducting a Safe Speed Study, as shown on the next page.

TOOLS FOR SPEED MANAGEMENT

A speed management program seeks to reduce both the overall number of vehicles exceeding the target speed and the even more dangerous high-end speeders.

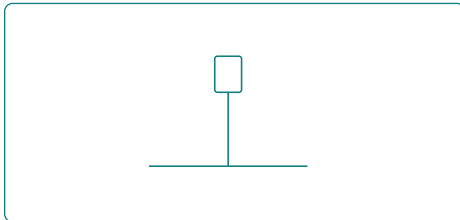

Signs & Markings

Signs and markings are necessary to communicate the speed limit and encourage safe speeds.

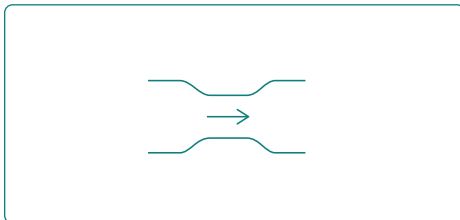

Design & Operations

Street design and operational changes are the most effective method for managing speeds. Street design is self-enforcing, making it a particularly powerful tool.

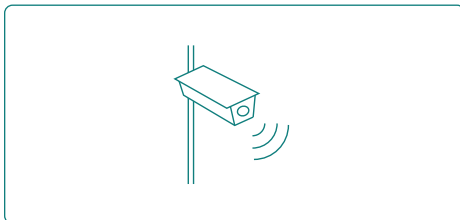

Automated Enforcement

Automated speed enforcement can be a useful component of speed management.

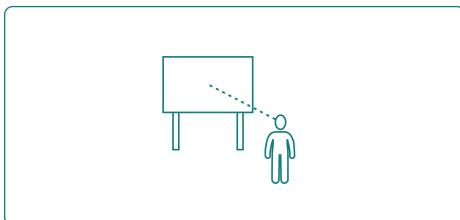

Messaging & Education

Marketing campaigns and education programs support cities’ efforts to reduce speeds through design and policy.

SELECTING A SPEED MANAGEMENT OPTION

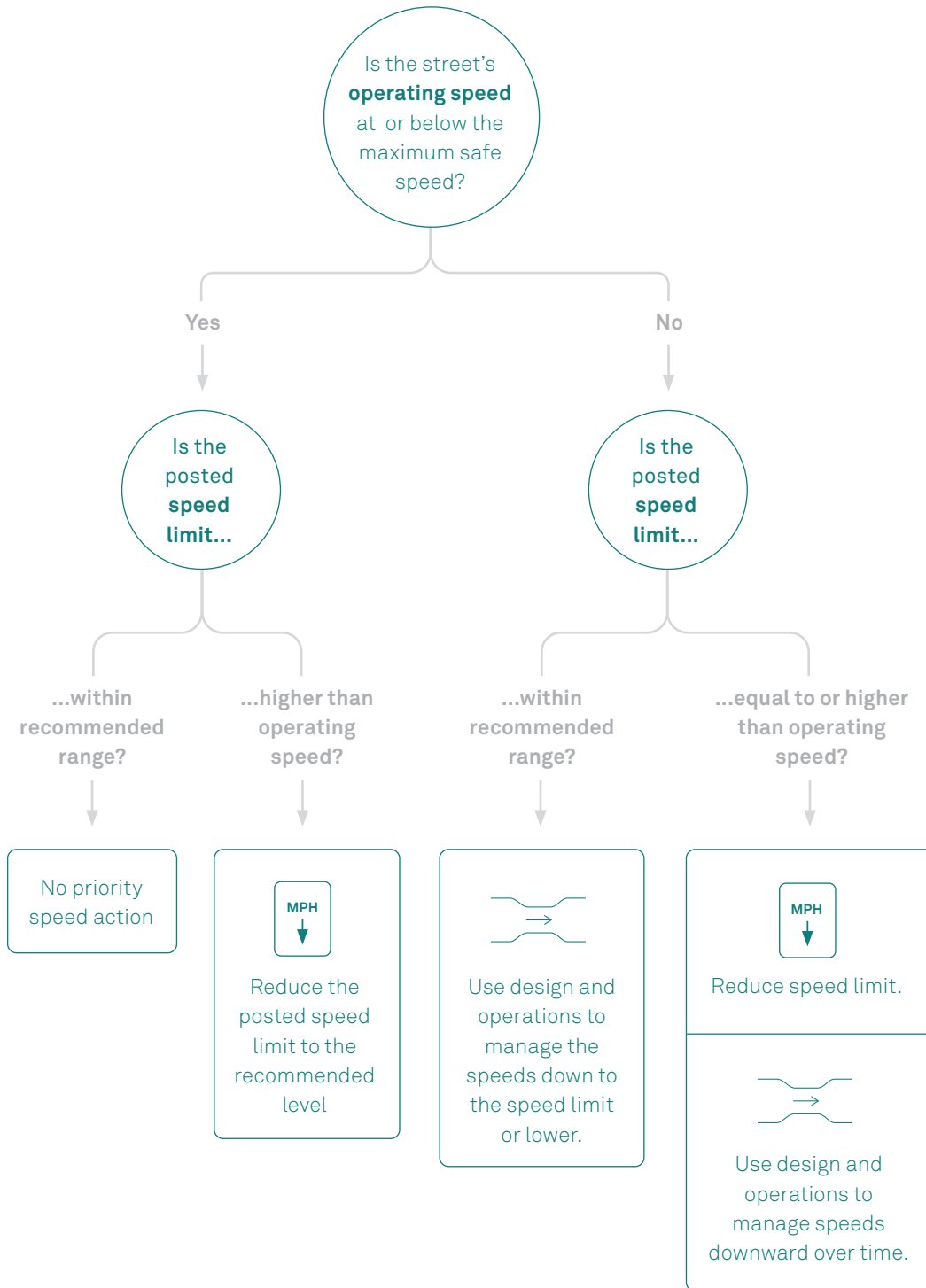

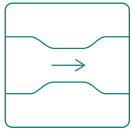

DESIGN & OPERATIONS

Street design and operational changes can reduce the number of opportunities drivers have to speed and reduce the top speeds at which motorists are comfortable driving. Most street design techniques reduce speeding in one of, or a combination of, three ways:



Making speeding physically impossible, usually through raised elements.

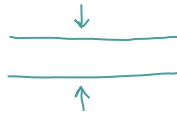

Reducing motor vehicle lane width to increase discomfort at higher speeds.⁶⁴



Adding gateway treatments or 'arterial slowpoints' that create visual cues to reduce speeds.

Arterials and other large urban streets present unique challenges for speed management. These streets typically feature high traffic volumes, higher posted speeds, both signalized and unsignalized crossing points, and multiple lanes. In total, arterials account for nearly a third of fatal crashes in the US, despite covering only 6% of roadways.⁵⁹ To address these challenges, cities will often need to deploy both design (street cross-section) and operational (signalization) tools to produce the necessary speed reductions. Combined, these tools can help the city achieve harmony between design speed, target speed, and the speed limit.⁶⁰

Examples of design changes include:

- › Reducing the number of general-purpose motor-vehicle lanes. With fewer lanes, off-peak vehicle capacity can be more closely matched to vehicle volume using signal timing methods.
- › Narrowing lanes, using excess space to add in-lane bus stops or bicycle or pedestrian facilities.

- › Adding street trees, shrubbery, or other neighborhood elements to indicate a different environment.
- › Adding speed cushions, raised intersections with gradual slopes, speed humps, or other bus- and emergency-vehicle-compatible raised elements.⁶¹
- › Converting turn lanes into pedestrian safety islands or curb extensions.
- › Repurposing under-utilized lanes for other modes or other needs.

Examples of operational changes include:

- › Reducing the length of signal cycles or green signal time on the major street, particularly at non-peak times.⁶²
- › Reprogramming signal timing for a lower progression speed, usually 2-3 mph below the target speed (for both one-way and two-way streets) or breaking progressions into shorter distances (for two-way streets).⁶³

DESIGN & OPERATIONS IN PRACTICE

BEFORE & AFTER - 10TH ST., ATLANTA



MASSACHUSETTS AVENUE REDESIGN - CAMBRIDGE

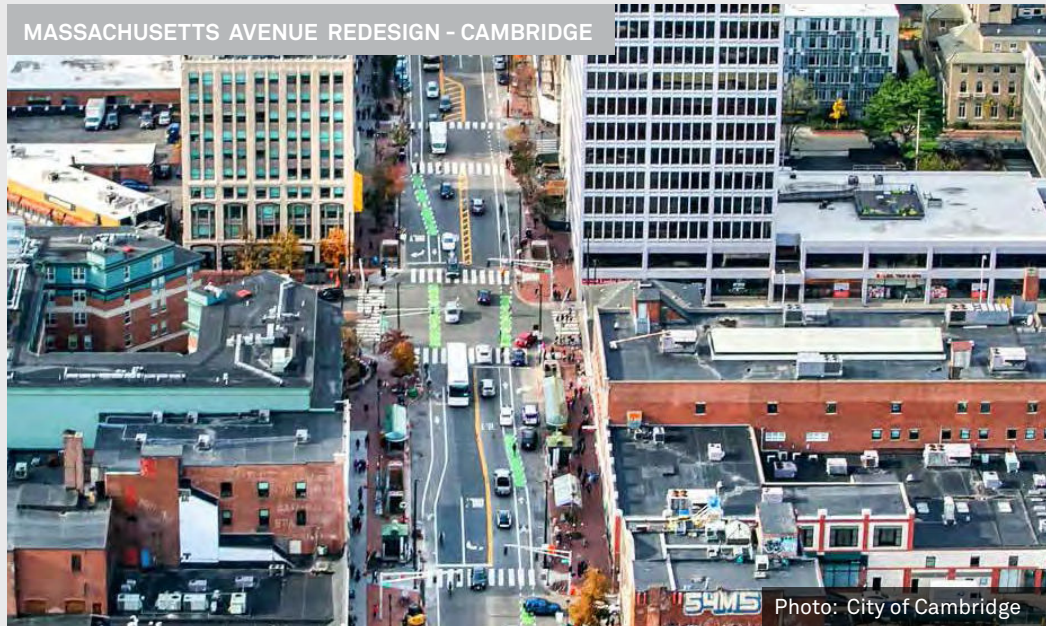

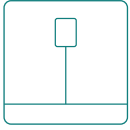

SIGNS & MARKINGS

Communicating new speed limits via signage and markings is essential for effectively managing speeds. Laws and policies about where speed limit signs should be placed vary from city to city. Placing identical speed limit signs on every block of a corridor where the speed limit never changes is costly and does not have proven speed-management benefits. However, preliminary studies out of Seattle show that increasing sign density to one sign every ¼ mile from one sign every mile does result in lower speeds and fewer crashes. At a minimum, cities should follow the guidance below about speed limit signs, making specific decisions about sign density and placement based on local context.

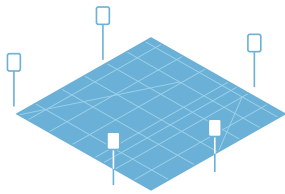

Cities with **default speed limits** or **category speed limits** should post “Speed Limit X Unless Otherwise Posted” signs at gateways into the city: highway off-ramps before an intersection, major streets at city limits, bridge and tunnel entrances, ferry terminals, and airport car rental facilities. Signs should be placed on any street that diverts from that default limit.

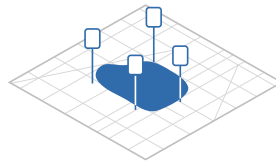

Cities with **slow zones** should post the limit for that zone at gateways into the designated area. On-street markings can also be utilized at the points where the speed limit changes or at key entrances to slow zones.

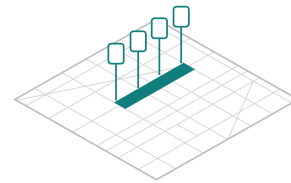

Cities with **major arterial slow zones and high-crash corridors** can post signs on those streets to reinforce the importance of adhering to the speed limit.

SIGNAGE & MARKINGS IN PRACTICE



Top left: Seattle DOT posts these signs at entrances into the city.

Top right: NYC DOT identifies arterial slow zones using special signage.

Bottom: Boston uses signs and on-street markings to alert drivers that they are entering a 20 mph slow zone.



AUTOMATED ENFORCEMENT

There is a long history of police officers using traffic stops to target people of color in the United States.⁶⁶ A Black driver is up to four times more likely to be stopped by a police officer than a White driver, and once stopped, Black drivers are up to five times more likely to be searched than White drivers.⁶⁷ In the US, enforcement has come to be the domain of the police, and police departments are an active partner in most, if not all, Vision Zero programs. However, recognizing the biased and sometimes deadly practices of US police forces, some cities and national organizations are reconsidering the role of police in making streets safe. Some options include: increasing emphasis on street redesign, automated speed enforcement or cameras, and more recently, moving traffic enforcement responsibilities out of police departments and into other agencies.

A growing body of evidence in places like Seattle, Boston, and Toronto shows that drivers respond to posted speed limits even without any enforcement efforts. On streets where operating speeds are consistently higher than the posted limit, cities should prioritize changes to street geometry over other tools. Changing the design and operations of streets to better match desired speeds and posted speed limits can often diminish the need for any enforcement, and is ultimately the most effective way to reduce speeds, fatalities, and injuries.

Automated speed enforcement (ASE) can be an effective tool for reducing operating speeds, especially in locations where data shows that there are frequent speed-related fatal and serious injury crashes.⁶⁸ Studies find that cameras reduce the percentage of speeding vehicles by 14–65% percent, and serious injury and fatal crashes by 11–44% percent.⁶⁹ Results from NYC's speed camera program found that, in the zones where cameras were installed, total crashes declined by 15%, total injuries by 17%, fatalities by 55%, and excessive speeding violations by 60%.⁷⁰

In particular, ASE programs are more effective at reducing speeding than manual enforcement because cameras are consistent and predictable for drivers. Data from NYC's speed camera program shows that, on average, daily violations at typical camera locations decline over time as drivers become aware of the cameras and drive more responsibly.⁷¹ NYC DOT also found that between 2014–2016, 81% of drivers do not receive more than one violation, further evidence that the cameras created an overall behavioral change.⁷²

When developing ASE programs, cities should keep several primary considerations in mind. First, while ASE technology itself may be impartial, cities must think critically about camera placement to avoid undue impacts on certain neighborhoods or communities. For example, cities often find that low income communities and communities of color experience higher than average serious injury and fatal crashes due to bad street design or underinvestment, leading them to disproportionately site cameras in those areas. Instead, in siting speed cameras, cities should simultaneously use crash data hotspot analysis to prioritize locations for street improvement projects, and evaluate regularly to determine if cameras are still necessary once the street has been changed. In addition, cities should layer multiple data points into camera placement analysis, including crashes and serious injuries, and the presence of schools, daycares, parks, and recreation and senior centers.

Second, cities should never use ASE to generate revenue. Instead, ASE should only be a tool for reducing speeds and/or achieving compliance with the posted speed limit. Especially when contracting with private ASE vendors, camera programs should be evaluated based on reductions in speed, not number of tickets issued. The distribution of camera locations, as well as the messaging behind enforcement, should match the goals of the program.

AUTOMATED ENFORCEMENT IN PRACTICE

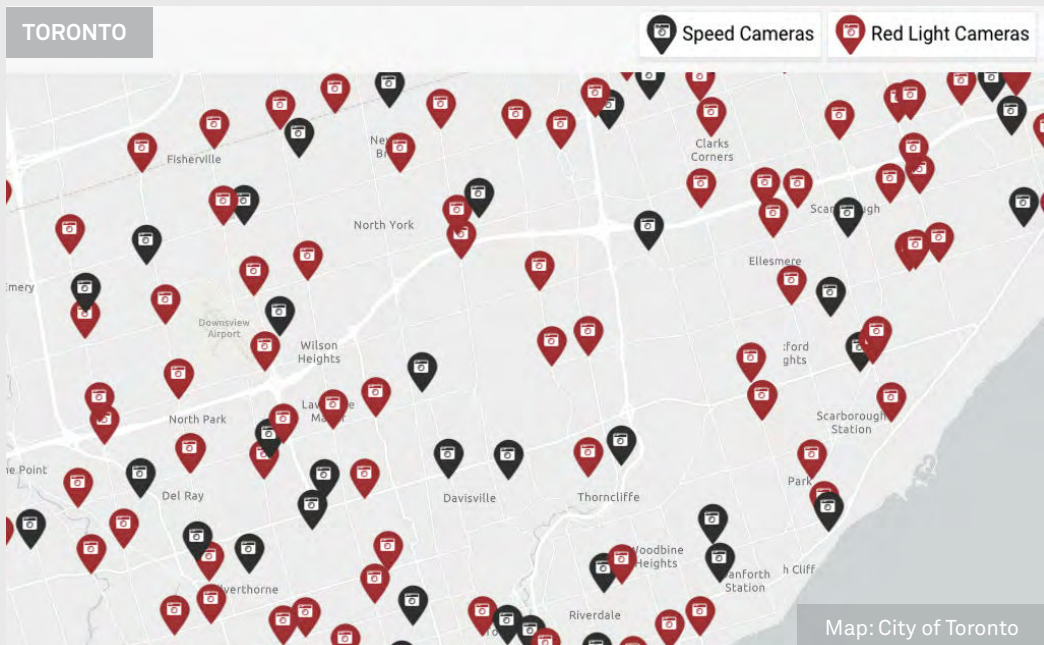

Top: A speed limit sign on Queens Boulevard in New York signals that speed limits are enforced by camera in some parts of the city.

Bottom: Toronto has an interactive online map that allows residents to see all active red light and speed camera locations.

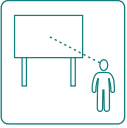

MESSAGING & EDUCATION

Communicating speed limit changes to the public is essential to a successful speed management program. Communications campaigns should begin well before implementation begins and continue after changes are in place. These campaigns serve a dual purpose, reminding the public about the policy rationale for reducing speeds—reducing traffic fatalities—while also preparing residents for the changes they will see on their streets.

Communications campaigns around speed limit changes should always link speed reductions with safety, constantly reminding the public, elected officials, and the media that reducing speed limits is a critical tool for reducing traffic deaths. Many effective campaigns focus on the people who are harmed by excessive speed, putting faces to the numbers. Others focus on reminding drivers that even small changes in their speed can increase the probability of surviving a crash.

Cities should be relentless and creative when spreading the word about speed limit changes. Examples include: TV, radio, and online ads, billboards, bus shelters, mailings, cross-promotional campaigns with local

sports teams, news stories, and op-eds. Free promotional materials such as buttons, stickers, and yard signs can extend the reach of an educational campaign beyond traditional media channels and outlets. For example, Portland, Seattle, Minneapolis, and others have distributed “20 is Plenty” yard signs as part of an education campaign about new 20 mph speed limits on residential streets.

City transportation departments should also look to incorporate speed reduction information into other city-issued collateral, including materials distributed by other agencies. For example, prior to reducing the citywide speed limit, New York City DOT added messaging about the new 25 mph limit to the backs of all municipal parking meter receipts.

Finally, community and advocacy partners are essential to successful campaigns. In New York, Families for Safe Streets, a group made up of the families and survivors of traffic crashes, regularly met with city and state-level lawmakers and was instrumental in pushing the NY State legislature to pass legislation authorizing a lower citywide speed limit.⁷⁴

MESSAGING & EDUCATION IN PRACTICE

PORTLAND

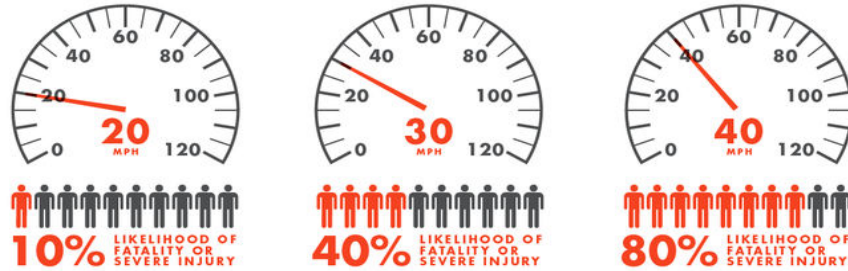

DEATH DUE TO SPEED

Graphic: City of Portland

NEW YORK CITY



Photo: NACTO

MINNEAPOLIS



Photo: City of Minneapolis

SANTA MONICA



Photo: City of Santa Monica

From top, clockwise: Portland's Vision Zero website includes graphics that clearly describe the relationship between speed and safety; Minneapolis Public Works disseminates "20 is Plenty" yard signs to spread the word about new lower speed limits in residential areas; Santa Monica uses brightly colored yard signs to remind drivers that children are present in this area; and New York City reminds drivers about the citywide speed limit on the back of municipal parking meter receipts.

4 ●●●●

Conduct an Evaluation

Determining the effectiveness of a speed limit change or safety project, and making further adjustments as necessary, is essential to reducing traffic fatalities. In addition, project data that shows how speed limit changes reduce speeding and can reduce fatalities is essential to making the case for future safety projects.

Cities should collect post-implementation data, mirroring the data that was collected before the project began, to conduct a full evaluation of their work. This data includes operating speeds, traffic incidents—paying special attention to fatal and serious pedestrian and cyclist injuries—conflict points, and speeding opportunities.

In collecting post-implementation data and conducting project evaluations, cities should remember that drivers typically adjust to speed limit changes slowly and therefore operating speeds may not change at all in the short-term. As tempting as it is to try to produce immediate results, cities should focus on reporting 6-month and 1-year after data for operating speeds to ensure a robust and accurate evaluation.⁷⁵ Transportation department leadership should prepare elected officials, policy makers, the media, and the public for some “lag-time” between project implementation and evaluation and results.

KEY METRICS

Key metrics for determining the effectiveness of a speed limit change or safety project include:

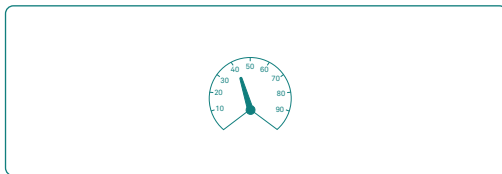

Change in the number of high-end or top-end speeders; change in operating speed

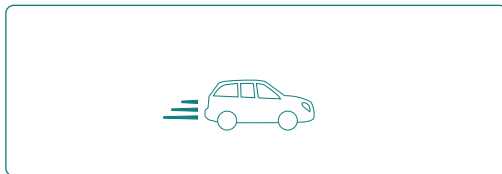

Change in the number of speeding opportunities



Change in the number of people killed or severely injured

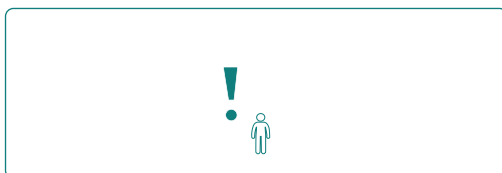

Change in conflict counts



CHANGES IN HIGH-END SPEEDING

On city streets, the most substantial risk comes from high-end speeding, even if it is typically only a small percentage of total traffic. As a result, changes in the number of high-end speeders is a primary metric for determining the efficacy of a speed limit change or safety project.

High-end speeding is measured as the number or percent of drivers exceeding specific, high-risk speed thresholds (e.g., over 30 or 35 mph, or greater than 10 mph over the target speed for most streets), in a typical 24 hour period.

Because high-end speeding is set to a specific threshold that does not change with the speed limit, this metric allows for apples-to-apples comparisons before and after a project or from site to site. The prevalence of high-end speeding is a better indication of risk than 85th percentile speed or the number of speeding vehicles, since there is sometimes a ‘long tail’ of high-end speeders.⁷⁶ Well-done speed management can result in a dramatic change in high-end speeding, even when 85th percentile or median speeds do not change dramatically.

CASE STUDY

RAINIER AVENUE, SEATTLE

Speed management and street design changes can substantially reduce the amount of high-end speeding on a street. On Rainier Avenue in Seattle, a 4-lane-to-3-lane conversion resulted in up to a 16% decrease in median speed, and up to an 81% decrease in drivers exceeding 40 mph.⁷⁷

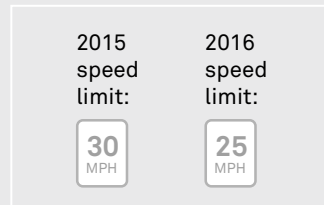

50TH PERCENTILE SPEED, NORTHBOUND



SPEEDERS (PERCENT SPEEDING)

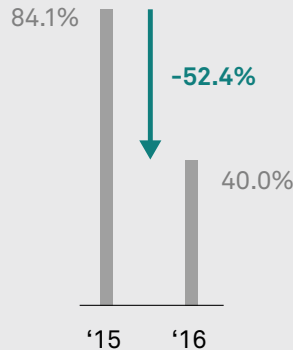

TOP END SPEEDERS (DRIVERS EXCEEDING 40 MPH)

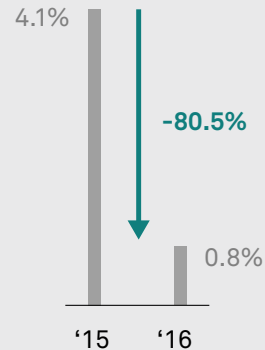



CHANGES IN SPEEDING AND OPERATING SPEEDS

Changes in the total number of people speeding and the overall operating speed provide information about the typical or median experience on the street or corridor. This metric is important to capture because it is the simplest. However, unlike high-end speeding, the number and percent of drivers exceeding the speed limit definitionally changes as the speed limit is reduced, so policy makers should be careful when using this metric to explain the impact of a project.

When necessary, the speed of the median or 50th percentile driver can be used to understand the typical experience on a street. Assuming traffic along the corridor is distributed normally, the majority of drivers will cluster around the median. A large difference between the median and 95th-percentile speed can indicate a high prevalence of high-end speeders or that there are too many opportunities to speed.



Photo: Cyrus Tetteh City of Detroit-CCSD⁷⁸

ANALYZING SPEED DATA

Methods for Documenting Speeds

Single-point speed studies help identify high-end speeding locations. Handheld radar, fixed-location radars such as those used for automated speed enforcement, speed feedback signs, and multi-tube vehicle counters are all sources of single-point speed data of varying quality and sample size.

Speed profiles show the range of speeds found along a street, making it easy to identify where vehicles speed up or slow down along a corridor. This data is increasingly available from city fleets or third-party providers.

Metrics for Documenting Speeds

Several metrics are applicable to Safe Speed Studies on urban streets and before-after evaluation.



High-end speeding: The number or percent of drivers exceeding specific, high-risk speed thresholds. (e.g., over 25 mph, over 30 mph, over 35 mph). A decrease within this indicator indicates effective speed management.

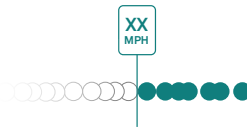

Speeding: The percent or number of drivers exceeding the speed limit.



Standard Deviation: The standard deviation of speeds indicates how much faster the high end of vehicle speeds are from the low end. A large standard deviation shows that speed varies greatly on the street, leading to less predictability and higher crash risk.



Median speed: The speed of the 50th percentile driver. This number can be used to understand the speed of typical drivers, rather than the fastest drivers.



85th percentile speed: The speed of the 85th percentile driver. Cities should not collect and report on 85th percentile speeds in isolation—95th percentile speeds and median speeds help round out the picture of dangerous speeds on the street.



95th percentile speed: The speed of the 95th percentile driver. This number can be used as an estimate of the fastest speed that a typical user will encounter, and can be used as a measure of how well speeds have been managed.



CHANGES IN FATAL AND SERIOUS CRASHES

Streets with a history of multiple people killed or seriously injured in traffic crashes over five years may have underlying safety risks that are likely to recur. Examining crash history by travel mode provides a basis for understanding the existing risks on the street. Even when “speed” or “speeding” is not listed on a crash report, speed may be an underlying factor; speeding is underreported in US traffic crashes, and speed at crash is not always available.⁷⁹ Further, fatal and serious injury crashes involving pedestrians, bicycles, and left turning vehicles often can be addressed in part through speed reduction. Cities should use data about fatal and serious injury crashes (when and where

they occurred, and what caused them) to both prioritize projects and make design and engineering decisions.

Short-term crash data can be unreliable, especially for the most serious crashes. Using three to five “before” years of crash data and evaluating how the “after” condition differs will help practitioners draw conclusions about the effectiveness of a safety project. Combining severe injury with fatality data is another way to improve the reliability of crash analysis at the project level.

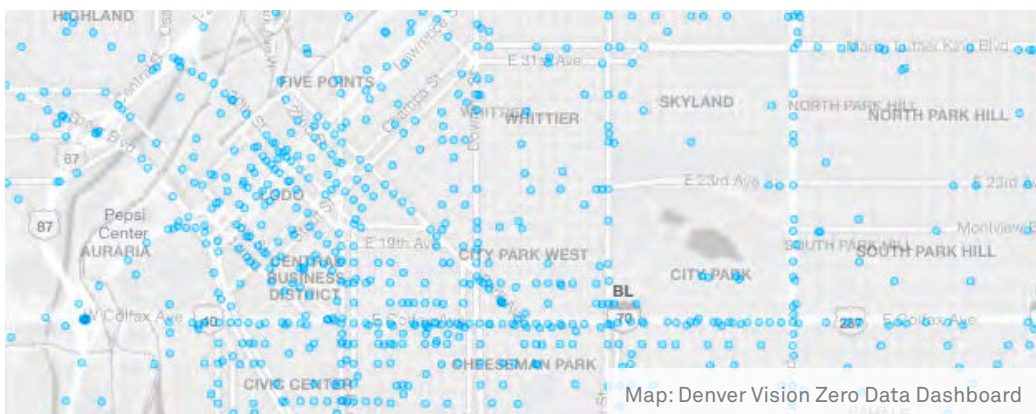

A five-year history of fatal and serious injury crashes can help practitioners understand the risks already present on a street. Denver uses a dashboard to track and display crashes on the street network. In addition to understanding where crashes happen, cities should also look into why they are happening, and use that to make decisions about street design and project prioritization.



CHANGES IN SPEEDING OPPORTUNITY

Speeding occurs where drivers are comfortable exceeding a safe speed because of the design of the street, and when they have an opportunity to speed because there are no other cars ahead. Streets with excess motor vehicle capacity at either peak or non-peak times tend to provide opportunities to speed. Similarly, multilane streets as well as signalized streets with long green phases and/or high-speed progressions provide, by definition, more opportunities to speed than a one-lane street.

Analyzing speeding opportunities on a corridor can provide planners with information about the best speed mitigation strategies, for example through signal operations changes, limiting the number of motor vehicle lanes, or repurposing motor vehicle lanes to other uses.

Speeding opportunity can be modeled as the number of motor vehicles arriving at a point no other vehicles have passed for a set time, such as five seconds. For example, for signalized intersections, drivers have a speeding opportunity if they arrive at the intersection on a green signal at least five seconds after the previous vehicle.

Speeding opportunity can also be discussed as a daily vehicle volume: a street with several hundred opportunities to speed per day will produce far fewer injuries than one with several thousand opportunities to speed per day, assuming each vehicle has a similar potential for conflicts. Speed management projects should aim to greatly reduce the number of speeding opportunities in a given street, corridor, or zone.





CHANGES IN CONFLICT COUNTS

Conflict counts are a surrogate measure of safety. They should be prioritized as part of a Safe Speed Study when changes to street design or activity levels mean that simpler measures, such as crash history, will not sufficiently approximate risks on the street.

Conflict counts are completed by observing the number of times per day or per hour that two people or vehicles are on a collision course and must take evasive action to prevent a crash. Common conflict classification methods for urban streets include time-to-collision

(if no evasive action is taken) or post-encroachment time (how soon after one participant passes a specific point does the other participant go through it).

Conflicts per entry (conflict counts divided by the vehicle and person-entries) into an intersection provide the likelihood that each person using the street at a particular location for a particular movement will be involved in a conflict.⁸⁰

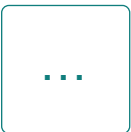

ADDITIONAL DATA

Several other street characteristics are routinely considered in speed limit studies, and may provide a starting point for determining appropriate design and engineering measures for speed management:

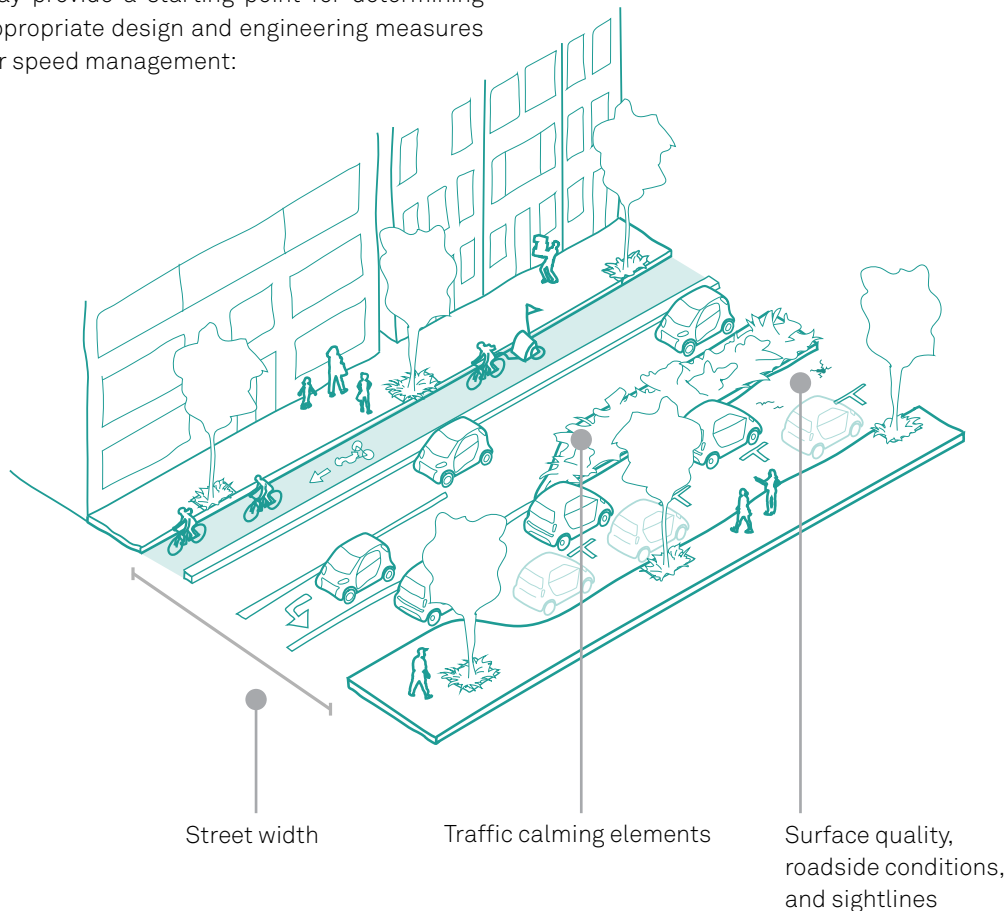

Section 3 Endnotes

53. Jurewicz, C., Sobhani, A., Woolley, J., Dutschke, J., Corben, B., (2016). Exploration of vehicle impact speed – injury severity relationships for application in safer road design. *Transportation Research Procedia* 14, 4247-4256.
54. Tefft, B.C. (2011). Impact Speed and a Pedestrian's Risk of Severe Injury or Death. AAA Foundation for Traffic Safety. Retrieved from: <https://aaaafoundation.org/impactspeed-pedestrians-risk-severe-injurydeath/>.
55. Jurewicz, C., Sobhani, A., Woolley, J., Dutschke, J., Corben, B., (2016). Exploration of vehicle impact speed – injury severity relationships for application in safer road design. *Transportation Research Procedia* 14, 4247-4256.
56. Federal Highway Administration. Functional Classification Concepts, Criteria and Procedures. Retrieved from: https://www.fhwa.dot.gov/planning/processes/statewide/related/highway_functional_classifications/section03.cfm.
57. Federal Highway Administration (2012). Methods and Practices for Setting Speed Limits. Retrieved from: https://safety.fhwa.dot.gov/speedmgt/ref_mats/fhwasa12004/fhwasa12004.pdf (page 10).
58. Ibid (page 26).
59. National Safety Council. Motor Vehicle Safety Issues: Speeding. Retrieved from: <https://injuryfacts.nsc.org/motor-vehicle/motor-vehicle-safety-issues/speeding/>.
60. National Highway Traffic Safety Administration. Fatality Analysis and Reporting System. Retrieved from: <https://www.nhtsa.gov/es/research-data/fatality-analysis-reporting-system-fars>.
61. Federal Highway Administration (2018). Self-Enforcing Roadways: A Guidance Report. Publication No. FHWA-HRT-17-098. Retrieved from: <https://www.fhwa.dot.gov/publications/research/safety/17098/17098.pdf>.
62. These treatments are appropriate for some major streets, but not large multi-lane arterials.
63. Furth, P. G., Halawani, A. T. M., Li, J., Hu, W. (Jake), & Cesme, B. (2018). Using Traffic Signal Control to Limit Speeding Opportunities on Bidirectional Urban Arterials. *Transportation Research Record*, 2672(18), 107–116. Retrieved from: <https://doi.org/10.1177/0361198118790638>.
64. Ibid.
65. Karim, Dewan Masud (2015). Narrower Lanes, Safer Streets. Accepted Paper for CITE Conference.
66. Photo: Bruce Englehardt/Seattle Transit Blog
67. Stanford Open Policing Project. Retrieved from: <https://openpolicing.stanford.edu/>.
68. Ibid.
69. National Highway Traffic Safety Administration (2016). System Analysis of Automated Speed Enforcement Implementation. Retrieved from: https://www.nhtsa.gov/sites/nhtsa.dot.gov/files/812257_systemanalysisase.pdf.
70. Centers for Disease Control and Prevention. Motor Vehicle Safety: Automated Speed-Camera Enforcement. Retrieved from: <https://www.cdc.gov/motorvehiclesafety/calculator/factsheet/speed.html>.
71. New York City Department of Transportation (2018). Automated Speed Enforcement Program Report 2014-2017. Retrieved from: <http://www.nyc.gov/html/dot/downloads/pdf/speed-camera-report-june2018.pdf>.
72. Ibid.
73. Ibid.
74. www.metouhey.com
75. Transportation Alternatives. Our Story. Retrieved from: <https://www.transalt.org/ourstory?rq=speed%20limit>.
76. Note that a simple before-after comparison may not show the true effect of a speed management project. The comparison does not control for other factors that may have affected the number of crashes or speeds. It is important to include an appropriate control group to control for these factors.
77. Federal Highway Administration (1998). Synthesis of Safety Research Related to Speed and Speed Management. Retrieved from: <https://www.fhwa.dot.gov/publications/research/safety/98154/speed.cfm>.
78. Seattle Department of Transportation (2017). Rainier Avenue South Safety Corridor: Rainier Pilot Project Evaluation. Retrieved from: https://www.seattle.gov/Documents/Departments/SDOT/MaintenanceProgram/RainierAveS_BeforeAfter.pdf (page 13).
79. Permission to use photo by K. Shabu Supervising Photographer.
80. Cherry, Christopher et al. (November 2018). Completing the Picture of Traffic Injuries: Understanding Data Needs and Opportunities for Road Safety. Collaborative Sciences Center for Road Safety. Retrieved from: http://www.roadsafety.unc.edu/wp-content/uploads/2018/11/CSCRS_R4_FinalReport.pdf.
81. More information on the major conflict techniques can be found at Kraay, J., et al. (2013). Manual conflict observation technique DOCTOR. *Road Safety for All*. https://www.ictct.net/wp-content/uploads/SMoS_Library/LIB_Kraay_et_al_2013.pdf.

NEW YORK CITY

Photo: NACTO

Was it
Worth it?
Slow down.

VISION ZERO

OUTFRONT

The billboard features a man in a blue and red jacket looking down at a bicycle accident scene. In the background, an ambulance is visible. The text 'Was it Worth it? Slow down.' is prominently displayed at the top. 'VISION ZERO' is written at the bottom left, and 'OUTFRONT' is written at the bottom right.





4

Checklists

Analyzing Existing Conditions & Using the Risk Matrix

These checklists are a starting point for analyzing how dense conflicts are on a given street and how active that street is, in order to determine a safe speed limit for a street.

To support quantitative analysis, cities can determine specific thresholds (e.g., What does “high pedestrian volume” mean in your city?) based on local conditions. This guidance avoids determining thresholds so as not to be overly prescriptive.



CONFLICT DENSITY ANALYSIS CHECKLIST

START:

IF any of these apply to the street...

No sidewalks

OR

Bicycle traffic in the traffic lane, even where marked or signed (e.g., sharrows)

OR

Sidewalks directly adjacent to moving traffic

OR

≥ 3 “through” or “T” intersections (signalized or unsignalized), major driveways, or other crossing points per ¼ mile

THEN the street has:

HIGH CONFLICT DENSITY

PROCEED to the Activity Analysis.

IF NOT, proceed...

IF the street has...

1-3 “through” or “T” intersections (signalized or unsignalized), major driveways, or other crossing points per ¼ mile

AND

Curbside loading/parking lane and sidewalk, or a USDG-compliant sidewalk

AND EITHER:

A marked bike lane or better, if designated bike route

OR

A full sidewalk with permissible bike use, if not a designated bike route

THEN the street has:

MODERATE CONFLICT DENSITY

PROCEED to the Activity Analysis.

IF NOT, proceed...

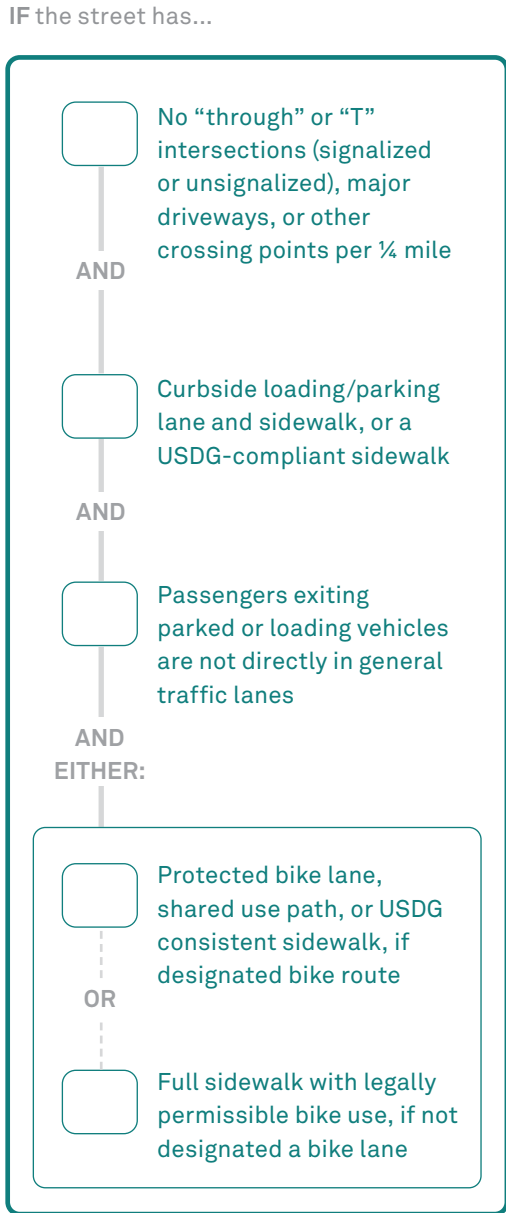

THEN the street has:

LOW CONFLICT DENSITY

PROCEED to the Activity Analysis.

Sample Conflict Density Metrics

There are many metrics that a city can use to measure a street’s conflict levels. The list below provides a starting point. Cities can set quantitative thresholds based on local conditions.

Pedestrian crossing volume per day or hour	Pedestrians walking in the street per hour
Left turn volume per day or hour	Midblock or uncontrolled-intersection crossings per hour per ¼ mile
Motor vehicle lane blockage or bike-lane blockage percent per hour	

RESULTS FOR: Conflict Density Analysis

! Based on the **conflict density** analysis, the street has:

- HIGH CONFLICT DENSITY**
- MODERATE CONFLICT DENSITY**
- LOW CONFLICT DENSITY**



ACTIVITY LEVEL ANALYSIS CHECKLIST

START:

IF the street is any of the following...

Downtown / Central Business District street

OR

Retail corridor

OR

High density residential or commercial street

THEN the street has:

HIGH ACTIVITY

PROCEED to the Risk Matrix to determine the correct speed limit for the street.

IF the street is a...

Moderate density residential or commercial street

OR

Street with light retail activity

OR

Mixed use corridor

THEN the street has:

MODERATE ACTIVITY

PROCEED to the Risk Matrix.

IF the street is a...

Low density industrial or residential street

THEN the street has:

LOW ACTIVITY

PROCEED to the Risk Matrix.

Sample Activity Level Metrics

There are many metrics that a city can use to measure a street’s activity levels. The list below provides a starting point. Cities can use land use metrics as an alternative in the absence of the volumes below. Cities can set quantitative high, medium, and low activity thresholds based on local conditions.

- | | |
|--|--|
| Pedestrian sidewalk volume per day or hour | Scheduled transit stops per hour |
| Bicycle volume per day or hour | Social and public space use volume per day or hour |
| Parking or curbside loading maneuvers per hour | Crash volumes by mode |

RESULTS FOR: Activity Level Analysis

Based on the activity level analysis, the street has:

<input type="checkbox"/>	HIGH ACTIVITY	<div style="width: 80%; background-color: #008080; position: absolute; left: 0;"></div>
<input type="checkbox"/>	MODERATE ACTIVITY	<div style="width: 40%; background-color: #008080; position: absolute; left: 0;"></div>
<input type="checkbox"/>	LOW ACTIVITY	<div style="width: 10%; background-color: #008080; position: absolute; left: 0;"></div>



APPLYING THE CONFLICT & ACTIVITY LEVEL ANALYSIS TO THE RISK MATRIX

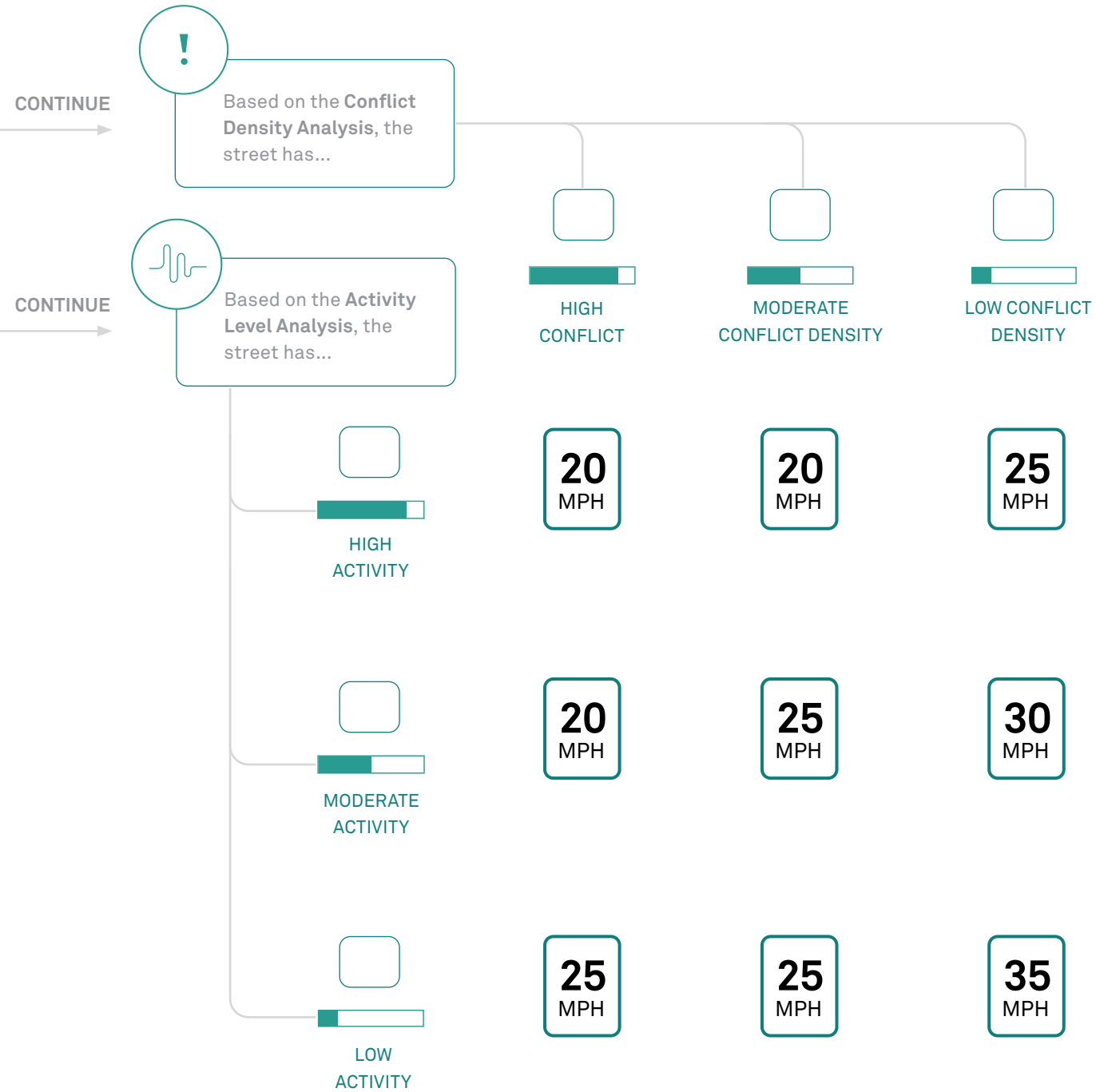

FINISH

Based on the analyses, the major street's speed limit should be:

<input type="checkbox"/>	20 MPH	<input type="checkbox"/>	25 MPH
<input type="checkbox"/>	30 MPH	<input type="checkbox"/>	35 MPH



National Association of
City Transportation Officials